



SEALERS

v. 2017

West Coast Plastics Equipment - Since 1945

Widest Selection!

800-392-8569



Gramatech Sealers p. 6,8,12

**WEST
COAST
PLASTICS**



Emplex
Band Sealers
p. 21-26,31



NEW!

VacPack IP66
Vacuum Sealer
p. 11

Quality Lines

Accu-Seal
Clamco
Emplex
Heat Seal
Packaging Aids Corp.
Plexpack
Sipromac
Vertrod

Audion Elektro
Damark
Gramatech
Kwik
PackRite
Promarks
TEW
Weigh Right



P.A.C. Pac-Vac p.13,14,17,50



Flow Wrappers
p. 48

**Order
Online
Securely**



NEW!

Clamco
Shrink
Wrappers
p. 41-47

WCPSEALERS.COM

Our “Plastics Equipment” Division . . .

In addition to our excellent line of Sealers, **West Coast Plastics Equipment, Inc.** also offers a line of plastics plant production equipment. With such lines as Watlow Heaters, Sensors & Controls, Durakool Mercury Relays, Price-Driscoll Mold Releases, MTS Temposonics Linear Transducers, Fenwal Thermoswitches & Detect-A-Fire, Amcot Cooling Towers and much more, we can supply your plant with the quality equipment it needs to keep you producing.

West Coast Plastics Equipment, Inc. has been serving Western Industry since 1945 in the plastics, packaging and related fields. Over 70 Years of supplying quality machinery, parts, accessories and service has made us the preferred source for production improving equipment.



Watlow Heaters

Band & Strip Heaters
Cartridge & Cable Heaters
Tubular Elements
Ceramic Fiber Heaters
Flexible Heaters
Immersion & Process Heaters
and more...



Watlow Controllers

Digital Temperature Controllers
Limit Controllers
Multi-Loop Controllers
Power Controllers
Solid State Relays
PC & Internet Connectivity
Data Loggers-NEW!



Watlow Sensors

Tube & Wire TCs
Mineral Insulated TCs
RTDs
Thermistors
TC Wire
TC Connectors



MTS MTS Temposonics Linear Transducers

Hydraulic Rod Style
Low Profile Style
Position Sensors
High Resolution
Digital & Analog Outputs
PC/PLC Communications



Price-Driscoll Mold Releases

12 Formulations for specific resins
3 Parfilm Releases
2 Universal Releases
Paintable
Mold Cleaners
Rust Inhibitor



FENWAL CONTROLS

Fenwal Thermoswitches

Tempswitches
Surface Mount Thermostats
Snap Disc Thermostats
Detect-A-Fire Sensors



amcot Amcot Cooling Towers

Fiberglass Construction
Compact & Lightweight
Economical
Wingert Separators



Durakool Mercury Displacement Relays

Silent, reliable switching
1, 2 and 3-pole
30-100 Amps
24V to 240V Coil voltage

For more info: www.watlow-distributor.com (for Watlow products), www.westcoastplastics.com (all the rest).

TABLE OF CONTENTS

Manual Impulse Sealers

Economy Hand Impulse Sealers 1
Economy Long Bar Impulse Sealers 1
Economy Foot-Operated Sealers 2
Hot Stamp Imprinters 2
Audion Sealmaster Magneta 3
Audion Sealboy 4
Audion Pronto Sealer 4
Audion Portable Hand-Held Sealers 5
Harwil Bar Sealers 5
Gramatech Portable Hand-Held Sealers 6
Vertrud Portable Hand-Held Sealers 6

Pneumatic & Motorized Sealers

Vertrud Steel-Frame Impulse Sealers 7
Vertrud Open-Back Impulse Sealers 8
Gramatech Pneumatic Impulse Sealers 8
Accu-Seal HDMP-3 Pneumatic Sealers 9
Economy Impulse Auto Sealers 9
PAC PI Pneumatic Impulse Sealers 10
PAC PT Table Top Impulse Sealers 10

Vacuum Sealers

Plexpack VacPack IP66 Vacuum Sealer 11
Poly Nylon Vacuum Bags 11
Gramatech GVS Vacuum Sealers 12
Gramatech Mighty Mutt 12
PAC Pac-Vac Impulse Vacuum Sealers 13
PAC Pac-Vac Barrier Vacuum Sealers 13
PAC Table Top Vacuum Sealers 14
Accu-Seal 675 Vacuum Sealers 15
Accu-Seal Budget Vacuum Sealers 15
Accu-Seal HDMP-3 Vacuum Sealers 16
Accu-Seal Machine Stand 16
PAC Coffee Pac Vacuum Sealers 17
PAC Fresh Pac Vacuum Sealers 17
PAC Bag-In-Box Vacuum Sealer 17
Audion-Vac Vacuum Chambers 18
Promarks Vacuum Chambers 19
Sipromac Vacuum Chambers 20
Emplex Band Sealer with Vacuum 21

Band Sealers

Emplex Band Sealer with Vacuum 21
Emplex MPS6000 Band Sealers 22
Emplex Conveyorized Band Sealers 23
Emplex MPS7000 Band Sealers 24
Emplex Semi-Automatic Seal System 25
Emplex InstaPack Automated System 25
Emplex Portable Band Sealer 26
Emplex Band Sealers Accessories 26
FRM-1120C Economy Band Sealer 27
HL-810e Economy Band Sealer 27
Audion 552 Horizontal Band Sealer 28

Medical Packaging

Medical Validation 29
Audion 552MED Band Sealer 29
PAC MedPac Validatable Sealers 30
PAC Table Top Validatable Sealers 30
Emplex Validatable Band Sealers 31
Accu-Seal 5300 Medical Sealer 32
Accu-Seal 6300 Medical Sealer 32
Accu-Seal 6400 Medical Sealer 33
Accu-Seal 8000 Medical Sealer 33

Baggers, Loaders & Weighers

Clamco Rollbag Demo Unit 28
Clamco R1275 Rollbag 34
Clamco R1075 Rollbag 34
Clamco R2300 Rollbag 35
Clamco 575B Rollbag 36
Weigh Right Scales 37
P.A.C. Flow Wrappers 48

Shrink Packaging

Economy I-Bar Shrink Sealer 38
Milwaukee Heat Gun 38
Shrink Film 38
Damark Semi-Automatic L-Bar Sealer 39
Damark Heat Tunnels 39
Damark Maxi-Pak Shrink System 40

Shrink Packaging (cont.)

Clamco Combo Jr. Shrink System 41
Clamco 1614 L-Bar Sealer 41
Clamco 820 Table-Top Shrink Tunnel 42
Clamco Automatic L-Bar Sealer 42
Clamco 120/240 Combo Shrink System 43
Clamco Heavy Duty L-Bar Sealer 44
Clamco Heavy Duty Shrink Tunnels 45
Clamco 4C/6C Combo Shrink Systems 46
Clamco Side Sealer 47
Heat Seal Magic Wand 49

Constant Heat / Barrier Sealers

Harwil Bar Sealers 5
PAC Pneumatic Barrier Sealers 50
Economy Constant Heat Sealers 50
PackRite Thermo-Jaw & Motor-Jaw 51
Audion Futura Portable Sealers 52
Kwik Constant Heat "Hot Jaws" 52
PackRite Hand Rotary Sealers 53
Heat Seal Model S Hand Irons 53

Other Sealers & Products

Hot Stamp Imprinters 2
Ingalls Conveyor Systems 36
Weigh Right Scales 37
Heat Seal Food Wrappers 49
Vacumaster Skin Packager 51
Heat Seal Portable Hot Plates 53
Accu-Seal Tube Sealers 54
Kwik Bag Loaders 54

Bags & Materials

Poly-Nylon Vacuum Bags 11
Shrink Film 38
Teflon Cloth & Teflon Tape 55
Nichrome, Wire & Connectors 55

BUSINESS HOURS

Open from 8:00 a.m. to 5:00 p.m. Monday through Friday. Call (800-392-8569) or fax (310-642-0468) in your order by 1:00 p.m. for same day shipment on stock items.

SHIPMENT

Orders are normally shipped via UPS or Fedex. Items that do not qualify for UPS or Fedex shipping will be sent via mutually arranged carrier. Shipping costs are not included in listed prices. A \$2.00 delivery surcharge and handling charge will be added to each order. Title to items being purchased passes from West Coast Plastics Equipment (WCPE) to purchaser at time of shipment. WCPE retains a security interest in the items until said items are paid for by the purchaser. If your shipment arrives damaged, you must note the damage on the carrier's delivery record in accordance with the carrier's policy, save the merchandise in the original box and packing it arrived in and notify WCPE immediately to arrange for a carrier inspection and/or pickup of damaged merchandise. If you do not notify WCPE of damaged goods within the first 10 days of arrival, WCPE cannot be liable for damage or replacement.

MINIMUM ORDER \$15.00

OPEN ACCOUNT ORDERS

West Coast Plastics Equipment will not release orders on Open Account unless credit has been established in advance. Call for a credit application.

CREDIT CARDS

For your convenience, Visa, Master Card, Discover and American Express are accepted by West Coast Plastics Equipment.

PRICING

Most prices listed in this catalog should be good to December 31, 2017, but are subject to change without notice.

AVAILABILITY

Your WCPE sales rep will inform you of the lead time of your products. Anticipated delivery dates are based upon vendor supplied information and are subject to change. WCPE will incur no liability for late delivery.

RETURN POLICY

Some items are not returnable to WCPE. Some returns are subject to manufacturer's return policies. Please clarify the return policy prior to your purchase.

WARRANTY DISCLAIMER

WCPE passes through to its customers all manufacturers' warranties and guarantees that are provided for the products it sells. WCPE makes no additional or independent warranties unless expressly stated prior to purchase. WCPE shall under no circumstance be liable for special, incidental or consequential damages. Please clarify the warranty policy prior to your purchase.



ECONOMY HAND IMPULSE SEALERS



TISH-100, TISH-200, TISH-300, TISH-400 Impulse Sealers

The **Hand-Operated Economy Impulse Sealers** by TEW are great for quick, easy, nice-looking seals at an economy price. Ideal for start-up or low-production needs. Available in 5 sizes to meet a wide range of packaging applications. Rated for approx. 300 bags / day to seal polyethylene and polypropylene bags up to 8 mil thickness. Available with standard 2mm wide seal or the wider 5mm seal. Models with cutter for trim sealing are also available.



TISH-200C Economy Sealer with Cutter

WCPE Model #	Mfgs Part #	Seal Length	Seal Width	Cutter	Sealer Price	Spare** Parts Kit	Nichrome Element	Teflon* Cover	Teflon Insulator	Silicone Rubber
WCH-100	TISH-100	4"	2mm	no	\$60.00	\$7.50	\$2.50	\$2.00	\$2.00	\$7.50
WCH-200	TISH-200	8"	2mm	no	\$70.50	\$7.50	\$2.50	\$2.00	\$2.00	\$7.50
WCH-205	TISH-205	8"	5mm	no	\$90.00	\$11.50	\$5.00	\$2.00	\$2.00	\$7.50
WCC-200	KF-200HC	8"	2mm	yes	\$112.50	\$8.50	\$2.50	\$2.00	\$2.00	\$7.50
WCC-205	KF-205HC	8"	5mm	yes	\$127.50	\$12.50	\$5.00	\$2.00	\$2.00	\$7.50
WCH-300	TISH-300	12"	2mm	no	\$105.00	\$9.50	\$3.00	\$2.50	\$2.50	\$9.00
WCH-305	TISH-305	12"	5mm	no	\$127.50	\$14.00	\$6.00	\$2.50	\$2.50	\$9.00
WCC-300	KF-300HC	12"	2mm	yes	\$142.50	\$10.50	\$3.00	\$2.50	\$2.50	\$9.00
WCC-305	KF-305HC	12"	5mm	yes	\$157.50	\$15.50	\$6.00	\$2.50	\$2.50	\$9.00
WCH-400	TISH-400	16"	2mm	no	\$135.00	\$11.00	\$3.50	\$3.00	\$2.50	\$12.00
WCH-405	TISH-405	16"	5mm	no	\$157.50	\$16.50	\$7.00	\$3.00	\$2.50	\$12.00
WCC-400	KF-400HC	16"	2mm	yes	\$165.00	\$12.50	\$3.50	\$3.00	\$2.50	\$12.00
WCC-405	KF-405HC	16"	5mm	yes	\$180.00	\$17.50	\$7.00	\$3.00	\$2.50	\$12.00
WCH-500	KF-520H	20"	2mm	no	\$150.00	\$14.50	\$4.50	\$4.00	\$3.00	\$15.00
WCH-505	KF-525H	20"	5mm	no	\$165.00	\$19.50	\$9.00	\$4.00	\$3.00	\$15.00
WCC-500	KF-520HC	20"	2mm	yes	\$195.00	\$16.50	\$4.50	\$4.00	\$3.00	\$15.00
WCC-505	KF-525HC	20"	5mm	yes	\$210.00	\$21.50	\$9.00	\$4.00	\$3.00	\$15.00

* High Volume roll (36 yards) of teflon cover \$75.00/roll. Knife blades for WCC units \$2.50 each.

** Spare Parts Kit includes 2 seal elements, 1 teflon cover, 1 teflon insulator and blade (WCC units only).

ECONOMY LONG BAR HAND IMPULSE SEALERS

The WN Series of **Long Bar Hand Sealers** is available in seal lengths of 26", 30" and 40" for large size bags and rolls of film. The seal width is 2.7mm. It also features an adjustable plug-in timer.

The WN Series also has models available with a cutter. The cutter is a sliding cutting blade that trims the bag or film 5/8" from the seal. There are also compatible Series WR film rollers to help when using rollstock film materials.

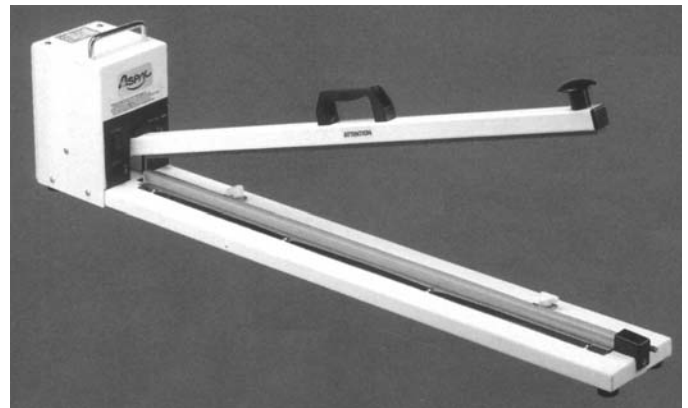

WN-750H Long Bar Sealer 30" (above)

Model No.	Description	Price	Spare** Parts Kit
WN-650H	Long Bar Impulse Sealer 26"	\$277.50	\$23.00
WN-750H	Long Bar Impulse Sealer 30"	\$330.00	\$29.00
WN-1000H	Long Bar Impulse Sealer 40"	\$537.00	\$36.00
WN-650HC	Long Bar Sealer w/Cutter 26"	\$322.50	\$26.00
WN-750HC	Long Bar Sealer w/Cutter 30"	\$390.00	\$34.00
WN-1000HC	Long Bar Sealer w/Cutter 40"	\$585.00	\$42.00
WR-650	Film Roller 26"	\$120.00	
WR-1060	Film Roller 42"	\$160.00	

** Spare Parts Kit includes 2 seal elements, 1 teflon cover, 1 teflon insulator and blade (HC units only).



WR-650 Film Roller 26" (right)



ECONOMY FOOT-OPERATED IMPULSE SEALERS



WCF-602 Economy Foot-Operated Sealer

The **Foot-Operated Economy Impulse Sealers** by TEW are ideal for larger bags and production volumes of 500-800 bags per day. Manually operated, the operator uses foot pressure to hold down the foot pedal through the entire seal cycle. With standard adjustable workshelf. Available in 5 seal lengths and 2 seal widths. For sealing heavier materials, there are three models with dual heat (top & bottom) elements.

The New **WN-Series (WCF-753 & WCF-903)** are available in 30" and 35" seal lengths with a 2.7 mm seal width. Materials up to 16 mil total thickness can be sealed. They are also capable of sealing 15-20 bags per minute. The sealers come with a 26" rectangular steel frame stand for safety and stability. It also comes with a working table with an adjustable plate.

WCPE Model #	Mfgs Part #	Seal Length	Seal Width	Dual Element	Sealer Price	Spare** Parts Kit	Nichrome Element	Teflon Cover	Teflon Insulator	Silicone Rubber
WCF-302	TISF-302	12"	2mm	no	\$333.00	\$21.00	\$3.00	\$15.00	\$2.50	\$10.00
WCF-305	TISF-305	12"	5mm	no	\$375.00	\$25.00	\$6.00	\$15.00	\$2.50	\$10.00
WCF-305D	W-300T	12"	5mm	yes	\$433.50	\$47.50	\$6.00	\$15.00	\$2.50	\$10.00
WCF-452	TISF-452	18"	2mm	no	\$382.50	\$24.00	\$4.50	\$15.00	\$3.00	\$13.50
WCF-455	TISF-455	18"	5mm	no	\$420.00	\$29.00	\$9.00	\$15.00	\$3.00	\$13.50
WCF-455D	W-450T	18"	5mm	yes	\$553.50	\$55.00	\$9.00	\$15.00	\$3.50	\$13.50
WCF-602	TISF-602	24"	2mm	no	\$427.50	\$24.50	\$4.50	\$15.00	\$3.50	\$18.00
WCF-605	TISF-605	24"	5mm	no	\$465.00	\$29.50	\$9.00	\$15.00	\$3.50	\$18.00
WCF-605D	W-600T	24"	5mm	yes	\$688.50	\$55.00	\$9.00	\$15.00	\$3.50	\$18.00
WCF-753	WN-750F	30"	2.7mm	no	\$525.00	\$32.50	\$5.50	\$18.00	\$4.00	\$22.50
WCF-903*	WN-900F	35"	2.7mm	no	\$720.00	\$37.00	\$6.50	\$20.00	\$5.00	\$27.00

* WCF-903 is oversize, must ship by truck.

** Spare Parts Kit includes 2 seal elements, 1 teflon cover roll, 2 teflon insulators (4 seal elements, 2 teflon cover rolls, 2 teflon insulators for dual element units).

HOT STAMP IMPRINTERS

Quick and easy usage for imprinting on poly bags, plastic cases, and paper products. For manufacturers of all types that need to code, date, number and identify with a permanent mark. Comes as a free standing unit or with no base for mounting on a sealer. Each unit is capable of printing from one to three lines of type, 9 characters per line. Includes a limited character set of drop-in type and a roll of foil printing tape for thousands of prints.

Model No.	Base	# Characters	Price
WCI-RS8	No Base	9 per line (1-3 lines)	\$420.00
WCI-RS20	With Base	9 per line (1-3 lines)	\$525.00
Rolls of foil printing tape 110 yds.			\$8.00
Character Set - A to Z			\$45.00
Characters - individual			\$3.00

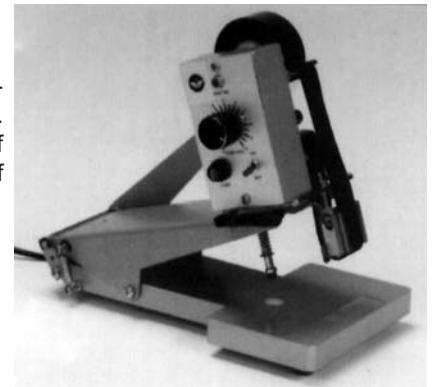

WCI-RS20 Hot Stamp Imprinter with Base.





AUDION SEALMASTER MAGNETA



Audion Sealmaster Magneta 421-MG

An industry standard for decades, the **Audion Sealmaster Magneta** is ideal for medium-duty applications of up to 1000-1200 bags per day. Used on PP/PE bags or film and light laminations up to 8 mil. The Sealmaster Magneta comes in five sealing lengths--12" (300 mm), 16.5" (421 mm), 24.5" (620 mm), 32" (820 mm), 40" (1020 mm). All models come standard with a 3mm wide seal, except the 820MGI and the 1020MGI which come with a 5mm wide seal.

MAGNETIC LOCK DOWN

It features featherlight operation and magnetic lock down of the seal jaws. The upper jaw can be closed by the slightest pressure of one finger or by an optional footpedal; then a powerful electromagnet holds the jaws closed while the bag is sealed. The sealing and cooling time is automatically cycled before the upper arm rises to release the sealed bag.

TIMER AND CUTTER

All Sealmaster Magnetas have a timer and sliding knife cutter as standard features. The Sealmaster can be mounted to a table/workbench or onto the optional footpedal stand. The timer regulates the heat cycle automatically for consistently good seals. The sliding knife cutter trims the bags for a clean finish 1/4" above the seal. The open back pass through design makes it ideal for use with layflat tubing. Use the optional rollers to give easy dispensing of the layflat tubing. And use the polylock to hold down the tubing before, during, and after the seal cycle. A workshelf completes the workstation.

EASY TO MAINTAIN

Very easy to maintain--the sealbar pops in and out in less than a minute and you are back in production. The new body style of the Sealmaster opens in the front or back giving easy access to the inside of the unit. Finally, the new head style is much easier to adjust with externally mounted adjustment bolts.

OPTIONS

Options for the Magneta include the foot-pedal stand (with foot-pedal), foot-pedal alone for bench mounting, poly-lock to hold down layflat tubing, work-shelf for product support, and rollers for stand.

ELECTRIC MODELS

NEW!! Electric Models. They are operated by the easy action of an electric foot switch. No manual operation, eliminates operator fatigue.



The entire line of standard Sealmaster Magnetas shown mounted on the optional foot-pedal stands with foot-pedals, poly-locks and rollers.



Audion 421-MGM shown with optional foot-pedal stand, work-shelf, poly-lock & rollers.

Model No.	Seal Length	Seal Width	Machine Price	Foot-Pedal Stand	Poly-Lock	Work-Shelf	Rollers & Poly-Lock
321-MG Magneta	12"	3mm	\$895.00	\$275.00	\$30.00	\$100.00	\$100.00
421-MG Magneta	16.5"	3mm	\$945.00	\$275.00	\$34.70	\$115.00	\$107.00
621-MG Magneta	24.5"	3mm	\$1,195.00	\$275.00	\$39.10	\$155.00	\$111.00
821-MGI Magneta	32"	5mm	\$1,930.00	\$355.00	\$52.10	\$170.00	N/A
1021-MGI Magneta	40"	5mm	\$2,090.00	\$450.00	\$69.40	\$200.00	N/A
421-MGS Magneta (st. steel)	16.5"	3mm	\$1,495.00	call	\$34.70	call	\$107.00
621-MGS Magneta (st. steel)	24.5"	3mm	\$1,940.00	call	\$39.10	call	\$111.00
421-MGM Magneta (electric)	16.5"	3mm	\$1,395.00	\$275.00	\$34.70	\$115.00	\$107.00
621-MGM Magneta (electric)	24.5"	3mm	\$1,695.00	\$275.00	\$39.10	\$155.00	\$111.00
421-MGT Magneta (twin seal)	16.5"	3mm	\$1,250.00	\$275.00	\$34.70	\$115.00	\$107.00
621-MGT Magneta (twin seal)	24.5"	3mm	\$1,690.00	\$275.00	\$39.10	\$155.00	\$111.00

See page 4 for replacement parts list.





AUDION PARTS

SEALMASTER, SEALBOY, MAGNETA & PRONTO PARTS

Part No.	Description	Price
8A17020	Codeseal Wire 10' Roll	\$23.00
2A17025	Control Knob	\$11.46
2A08025	Foot (Sealboy)	\$3.00
5A17581	Footpedal Assembly	\$90.00
2A052003	Fuse-Power Line-8 Amp	\$2.66
2T55297	Fuse-Sealbar-16 Amp	\$10.95
2A08503	Handle (Sealboy)	\$15.00
8A17021	Holding Rubber 10' Roll	\$38.30
2A17004	Housing Socket U/L	\$14.20
8A18507	Knife 3 pack	\$10.00
8A23102	Knife 3 pack-retracting	\$10.00
5A17565	Knife Assembly (non-retracting)	\$40.00
5A23102	Knife Assembly (retracting)	\$40.00
5A09578	Knife Assembly (Sealboy-retracting)	\$40.00
2A17062	Microswitch (w/roller)	\$15.55
2A48505	Microswitch (new)	\$31.61
2A08542	Microswitch (Sealboy)	\$16.00
2E24585	On-Off Switch	\$30.69
2A17065	Power Cord U/L	\$20.46
5A14524	Sealbar - 230	\$30.00
5A08512	Sealbar - 235	\$27.60
5A11524	Sealbar - 236 Sealboy	\$30.00
5A05530	Sealbar - PRA255 Pronto	\$27.60
5A23124	Sealbar - 300	\$34.00
5A48523	Sealbar - 321	\$34.00
5A17524	Sealbar - 420	\$37.30
5A48124	Sealbar - 421	\$37.30
5A20524	Sealbar - 580	\$42.40
5A49124	Sealbar - 620/621	\$42.30
8A17015	Sealbar Cover 10' Roll	\$50.00
8A17015L	Sealbar Cover 108' Roll	\$135.00
8A17017	Sealbar Insulator 10' Roll	\$30.00
2A17505	Sealbar Terminal Socket	\$5.12
8A23100	Sealing Rubber (Sealmaster-new style)	\$68.00
8A48516	Sealing Rubber (Magnaeta) 10' roll	\$68.00
8A17018	Sealing Wire 25' Roll	\$11.00
8E60001A	Sealing Wire 820-MG (3 pack)	\$84.80
2E58001	Sealing Wire 1020-MG (each)	\$33.86
8A17008	Terminal Plug Kit 2-pack	\$20.80
2A50440	Timer (screw terminal connectors)	\$149.26
2A056013	Timer (combination)	\$223.01
2A056021	Timer (combination)	280.71
2A23101	Timer Control (new Style)	\$30.18

AUDION SEALBOY



Audion Sealboy Model 236-SBSA with timer & cutter.

The industry standard for decades, the **Audion Sealboy** is a manually operated table top hand sealer. Rugged, high-quality construction for large workloads of up to 1000-1200 bags per day. Seals PP/PE bags/film to 10 mil. Comes in 2 models: 236-SBSA (9") with timer & cutter, 321-SBSA (12") with timer & cutter. Units with sliding knife cutters trim the bag approx. 1/4 inch above the seal line.

Very easy to maintain--the sealbar pops in and out in less than a minute and you are back in production.

Model No.	Description	Price
236-SBSA	9" Seal with timer & cutter	\$425.00
321-SBSA	12" Seal with timer & cutter	\$495.00
Options		
RL321	Rolloflux rollers for poly tubing	\$70.00
OT235	Workshelf	\$55.00

AUDION PRONTO BAG SEALER

The flexible **Audion Pronto Impulse Bag Sealer** can be wall mounted or table mounted on a work bench. It is a small bag sealer which can be used where space is limited. The Pronto sealer has been designed to seal plastic bags. With a timer, the correct sealing time can be set according to the bags you are using.

The machine is easy to operate. Once the bag is filled, it is placed between the sealing bars. With a simple push on the back plate, the bar will close and the sealing cycle will start. A control light is lit during the seal cycle.

An optional Pronto Stand is also available. It comes with two hooks for hanging wicketed bags.

The Pronto is very easy to maintain -- the sealbar pops in and out in less than a minute and you are back in production.

Standard Features Include:

- Seal width: 3/32" (2mm)
- Seal length: 10" (255mm) or 16" (420mm)
- Maximum bag thickness (PE): 2 x 8 mil (.008)
- Unit requires 115 volt/60 Hz electrical



The Audion Pronto PRA-255 Impulse Sealer can be used mounted on a wall (as shown) or table.

Part No.	Description	Price
PRA-255	10" Audion Pronto Impulse Sealer with timer	\$560.00
PRA-420	16" Audion Pronto Impulse Sealer with timer	\$840.00
PTS-255	Optional Pronto Stand	\$150.00



West Coast Plastics Equipment Inc., 623 S. Hindry Ave., Inglewood, CA 90301 (new address)

CALL TO ORDER 800-392-8569 / 310-215-3186 or FAX 310-642-0468 01/17

Web Page: www.wcpsealers.com E-Mail: sales@westcoastplastics.com



PORTABLE HAND-HELD IMPULSE SEALERS

GXHS-15
T-Clamp Style



Model GXS-10
Scissors Style Sealer

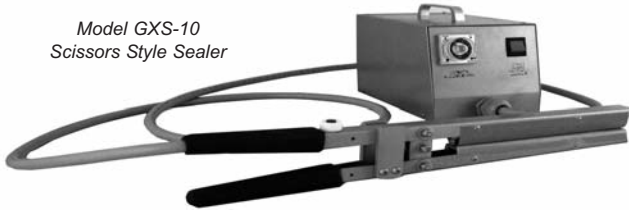

Gramatech's Impulse Hand Held sealers are ideal for sealing polyethylene and laminated foils. Applications include sealing around oddly shaped products including drum or box liners or for sealing around large objects such as furniture.

Each sealer is lightweight and portable. The operator simply squeezes the handles to open the jaws and clamps on to the film being sealed. A start button located on the seal jaw is activated. An indicator light on the main housing signals the start and finish of the seal cycle.

The heat cycle is controlled by a timer on the main housing. The operator simply increases or decreases the heat as desired. Upon completion of the cycle, the operator again squeezes the jaw, releasing the sealed product. All controls are solid state. An eight foot power line cord and eight foot sealer cord is standard. All units come standard with a 1/4" seal width.

Options include flat band elements (3/8 or 1/2 inch), dual elements (top & bottom heat), quick disconnect and 220 Volt electrical. Each unit comes complete with a two-year warranty on defective parts and 90-day warranty on labor, detailed operating instructions, and a spare parts kit.

GXHS-26
T-Clamp Style



Model #	Seal Length	Seal Width	Price
GXHS-8 (T-Clamp)	8"	1/4"	\$890.00
GXHS-12 (T-Clamp)	12"	1/4"	\$920.00
GXHS-15 (T-Clamp)	15"	1/4"	\$950.00
GXHS-18 (T-Clamp)	18"	1/4"	\$995.00
GXHS-26 (T-Clamp)	26"	1/4"	\$1,590.00
GXS-6 (Scissor)	6"	1/4"	\$870.00
GXS-10 (Scissor)	10"	1/4"	\$890.00
Options:			
3/8" Seal Width			\$325.00
1/2" Seal Width			\$350.00
Dual Element			\$225.00-300.00
Quick Disconnect Cable			\$400.00
220 Volt Electrical			\$350.00

HARWIL BAR SEALERS



Harwil Model T-7S Bar Sealer

The **Harwil Bar Sealers** are very easy to use just pick up and press down like a rubber stamp. It straightens, holds and seals in one step. The heat element bar is retracted inside the housing until you press down, then you apply pressure to make the seal. Seal all heat-sealable plastics, coated paper, metal foils, etc. from 1/4 mil to 6 mil thickness. Temperature ranges vary by model, see price chart below. Sealing time 1/2 to 2 seconds. Optional mounting base available for the T-7S & T-13P models.

Model No.	Description	Temperature Range	Price
T-7S	7" Seal Length	Thermostatically Controlled 150-300°F	\$175.10
T-13P	13" Seal Length	Factory preset at 350°F	\$147.90
T-13P/HT	13" Seal Length	Factory preset at 400°F	\$175.10
T-BAR-CB	Mounting Base for T-7S & T-13P models		\$41.70
FOB: Inglewood, CA			

West Coast Plastics Equipment Inc., 623 S. Hindry Ave., Inglewood, CA 90301 (new address)
 CALL TO ORDER 800-392-8569 / 310-215-3186 or FAX 310-642-0468 01/17
 Web Page: www.wcpsealers.com E-Mail: sales@westcoastplastics.com



VF → PORTABLE HAND-HELD IMPULSE SEALERS

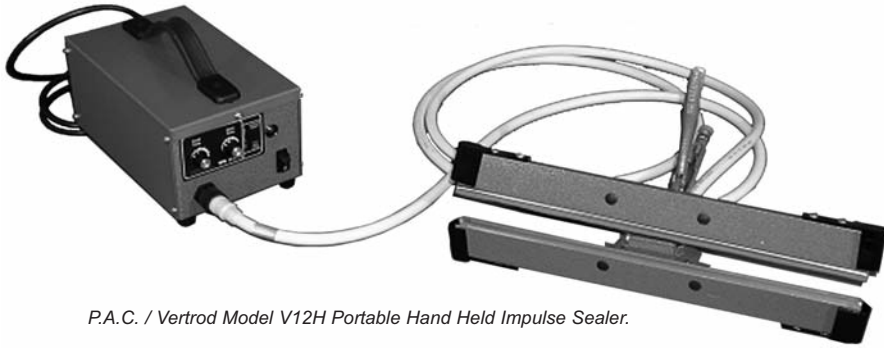

P.A.C. / Vertrod Model V12H Portable Hand Held Impulse Sealer.

The P.A.C. / Vertrod Portable Hand Held Impulse Sealer is ruggedly constructed, light weight, and is designed for packaging and fabricating applications where the sealing jaws must be brought to the work. The sealing jaws are built with a positive locking "vise" grip for strong holding pressure during the sealing cycle.

This series of heat sealers are available in a variety of different working lengths to fit your packaging needs. The features listed below are for the standard sealer configuration.

Standard Features:

- Seal width: 1/8"
- Seal lengths: 8", 12", 18", 24"
- Single sided heater bar with opposing pressure bar (optional bi-active-both jaws heated)
- Locking vise grip style jaws
- Separate impulse generator power box
- Time based thermal impulse control system
- Independent seal cycle & cool cycle timers
- Red & green cycle indicator lights
- Manual, hand operated

Model #	Seal Length	Seal Width	Base Price	Optional Bi-Active	Optional 1/4" Seal
V8H	8"	1/8"	\$1,160.00	\$790.00	\$455.00
V12H	12"	1/8"	\$1,320.00	\$790.00	\$455.00
V18H	18"	1/8"	\$1,475.00	\$1,585.00	\$805.00
V24H	24"	1/8"	\$1,635.00	\$1,585.00	\$805.00

Options:
Trim Sealing Pressure Bar (cut wire) call
FOB: Factory, Berea, Ohio.

PA → AUDION SUPER POLY PORTABLE SEALERS



The Audion Super Poly Portable Hand Impulse Sealer family with 3 sizes of jaw and impulse generator box (included)

From Audion, a company that has brought you quality bag sealing equipment for over 35 years, comes the "Super Poly" Portable Hand Impulse Sealer. This new design has hand-operated lightweight jaws that are easily carried to the product that needs to be sealed. The jaws are connected by a 16-foot cable to the impulse generator box which is also lightweight and portable. It is ideal for sealing around large and bulky products that cannot be carried to a stationery sealer.

The "Super Poly" features three different jaw widths -- 11", 15", 25" -- each of which is interchangeable on the same impulse generator box. Another outstanding feature of the "Super Poly" are the bi-active (top & bottom heat) jaws which give the "Super Poly" the power to seal thicker, harder to seal materials. The seal timer is adjustable for various types and thicknesses of materials. If the 16-foot cable is not long enough for your application, an optional 16-foot extension cable is available.

Also available is the H18 Super Poly Navy Portable Sealer. It has bi-active sealing with 18" long x 3/16" wide seals on both jaws. The jaw assembly is mounted on a 15-foot long cord with a bayonet connection to the Super Poly Power Module. The Navy model has a preset non-adjustable seal timer for poly bags. The Super Poly Jaw assemblies can be purchased individually for use with existing Super Poly Power Modules.

All Super Poly Portable Sealers use 115 volt, 60 Hz electrical.

Part #	Seal Length	Seal Width	Price
281SP	281 mm (11")	3 mm (1/8")	\$1,230.00
381SP	381 mm (15")	3 mm (1/8")	\$1,390.00
631SP	631 mm (25")	3 mm (1/8")	\$1,550.00
H18 Navy	450mm (18")	3/16"	\$2,327.33

Options:
SP-EXT 16 ft. Bayonet Extension Cord \$195.00
FOB: San Rafael, CA.



VERTROD HEAVY-DUTY IMPULSE SEALERS

STEEL-FRAME PNEUMATICALLY POWERED SEALERS



P.A.C. Vertrod Model V48PS Steel-Frame Impulse Sealer.

Packaging Aids Corp. has acquired the Vertrod Technaseal line of impulse sealers and improved the design of this industry standard. This ruggedly constructed heavy-duty open-back welded frame thermal impulse heat sealer includes safer pneumatics and P.A.C.'s state-of-the-art solid state PCB control circuitry. Designed for hard workloads of high temperature, thick material and difficult multi-wall packaging and fabricating applications. These sealers are capable of producing quality airtight/watertight seals in many materials ranging from seal temperatures of 200°F to 650°F.

Standard features include: 1/4" seal width, thermal impulse control system, open-back feed through body style, rotary switch timer for each stage of seal & cooling, foot switch actuation, all pneumatic safeties, 230 VAC electrical, compressed air operated at 90PSIG.

Optional extra cost features available include: top & bottom heater bars, water cooled heater bar, trim sealing pressure bar, temperature control system, scrap blow-off (with trim sealing pressure bar only), wider seal (3/8"), small water recirculating package, water chiller.

Standard features include:

- Seal lengths: 36", 48", 60", 72", 84", 96"
- Seal width: 1/4"
- Open-back feed thru style
- Welded frame construction
- Pneumatic and electric safeties
- Compressed air operated: 90PSIG
- Thermal Impulse control system.
- Rotary switch timers for each stage of seal and cool
- 230 VAC, single-phase operation
- Foot switch activated

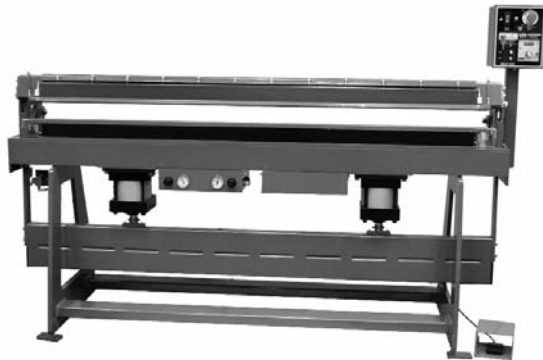

P.A.C. Vertrod Model V72PS-SP Steel-Frame Impulse Sealer.

Model #	Seal Length	Seal Width	Base Sealer Price	Optional Cold Wire Trim Seal	Optional Water Cool Heater Bar	Optional 3/8" Seal Width
V36PS	36"	1/4"	\$11,825.00	\$335.00	\$535.00	\$2,250.00
V48PS	48"	1/4"	\$13,110.00	\$335.00	\$535.00	\$2,250.00
V60PS	60"	1/4"	\$15,070.00	\$430.00	\$670.00	\$2,390.00
V72PS	72"	1/4"	\$17,215.00	\$430.00	\$670.00	\$2,390.00
V84PS	84"	1/4"	\$19,920.00	\$515.00	\$805.00	\$3,050.00
V96PS	96"	1/4"	\$22,260.00	\$515.00	\$805.00	\$3,050.00
Other Options:			Price			
Water Recirculating Package			\$515.00			
Water Chiller			\$3,935.00			
Heater Bar on Top, Pressure Bar on Bottom			\$280.00			
Ported Exhaust			\$305.00			
Scrap Blow-Off (with trim seal only)			\$455.00			
Anti-tie down dual palm controls			\$1,315.00			
Temperature Controller with digital readout			\$1,790.00			
FOB: Factory, Berea, Ohio.						





GRAMATECH PNEUMATIC IMPULSE SEALERS



Gramatech GXPS-21
Stainless Steel Sealer

The **Gramatech Model GS pneumatic impulse sealers** are completely stainless steel, making them ideal for food, cosmetic, clean room and other applications. They also come standard with top & bottom heat jaws that make a 1/4" wide seal. The new PLC Control System with color touch screen interface gives the operator a great deal of flexibility and control to achieve excellent and consistent seals. The pneumatic safety system utilizes a back-pressure sensitive microswitch to prevent the machine from locking the jaws down if any unwanted object is present in the seal area.

Pneumatically powered, the GS Series requires compressed air at 100psi and runs on standard 110V electrical. The GS can be operated on a benchtop or mounted on the stainless steel stand where it can be pivoted from horizontal to vertical to meet your packaging needs.

Gramatech Pneumatic Impulse Sealer

Model #	Seal Length	Seal Width	Price
GXPS-21TS	21"	1/4"	\$3,995
GXPS-26TS	26"	1/4"	\$4,495
GXPS-31TS	31"	1/4"	\$5,495
GXPS-36TS	36"	1/4"	\$5,995
GXPS-51TS (large body)	51"	1/4"	\$7,595
GXPS-61TS (large body)	61"	1/4"	\$8,095

Options & Accessories:

Stainless Steel Stand-Standard	\$895
Heavy Duty Stainless Steel Stand	\$1,700
Stainless Steel Shelf for Stand	\$395
Stainless Steel Feeder Tray	\$310
Stainless Steel Stand for Large Body Units	call
Stainless Steel Shelf for Large Body Units	call
Spare Parts Kit - varies by model	call
3/8" Wide Seal	\$500
220VAC Conversion	\$450
Continuous Heat Seal	\$2,495
Temperature Control Sealing Option	\$3,000
Clean Room Ready	\$210
FOB: Factory, Commerce, CA.	

VERTROD HEAVY-DUTY IMPULSE SEALERS

OPEN-BACK CABINET STYLE SEALERS

Packaging Aids Corp. has acquired the Vertrod Technaseal line of impulse sealers and improved the design of this industry standard. This ruggedly constructed open-back floor standing cabinet model thermal impulse heat sealer includes safer pneumatics and P.A.C.'s state-of-the-art solid state PCB control circuitry. Designed for hard workloads of multiple work shifts for up to six days per week. These sealers are capable of producing quality airtight/watertight seals in many materials ranging from seal temperatures of 200°F to 650°F.

Standard features include: 1/8" seal width, thermal impulse control system, open-back feed through body style, floor standing cabinet, rotary switch timer for each stage of seal & cooling, foot switch actuation, all pneumatic safeties, 115 VAC electrical, compressed air operated at 100PSIG.

Optional extra cost features available include: top & bottom heater bars, 230VAC electrical, water cooling, trim sealing pressure bar, scrap blow-off (with trim sealing pressure bar only), wider seal (1/4" or 3/8"), small water recirculating package, digital temperature controller, and work shelf.

Model #	Seal Length	Seal Width	Price	Cut Wire	1/4" Seal	Water-Cool
V14P-OB	14"	1/8"	\$5,565.00	\$160	\$805	\$275
V20P-OB	20"	1/8"	\$5,810.00	\$160	\$805	\$275
V24P-OB	24"	1/8"	\$6,955.00	\$245	\$1,005	\$405
V30P-OB	30"	1/8"	\$7,545.00	\$245	\$1,005	\$405
S.S. Adjustable Work Shelf			\$585.00 / \$715.00			
Optional Water Recirculating Kit			\$515.00			
Optional Scrap blow-off			\$455.00			
Digital Temperature Controller			\$1,790.00			
Water Chiller			\$3,935.00			
FOB: Factory, Berea, Ohio.						



P.A.C. Vertrod Model V30P-OB Open-Back
Cabinet style sealer.



West Coast Plastics Equipment Inc., 623 S. Hindry Ave., Inglewood, CA 90301 (new address)

CALL TO ORDER 800-392-8569 / 310-215-3186 or FAX 310-642-0468 01/17

Web Page: www.wcpsealers.com E-Mail: sales@westcoastplastics.com



ACCU-SEAL HDMP-3 SEALER

The **Accu-Seal HDMP-3 Sealers** have the Power and Control it takes to handle virtually any sealing, vacuum sealing or modified-atmosphere packaging application.

The HDMP-3's user selectable Dual Side or Single Side Heating and High Pressure Seal Bars, make this sealer series ideally suited for applications that previously were a challenge for one machine to handle. The open-ended jaw design enables coupling with a conveyor system for end-to-end through-put for a high capacity sealing station.

The HDMP-3 is built Accu-Seal tough. A "Muscle Machine," designed for flexibility and years of reliable trouble-free performance. The HDMP-3 withstands the harshest environments of industrial, electronics, chemical, food and perishable product packaging.



Accu-Seal Model HDMP-3 Heavy-Duty Wide Jaw Impulse Sealer

HDMP3 Series Seal-Only Impulse Sealers			
Model	Seal Width	Seal Length	Price
HDMP3-232	1/4"	20"	\$6,298.00
HDMP3-332	1/4"	25"	\$6,498.00
HDMP3-432	1/4"	30"	\$6,798.00
HDMP3-532	1/4"	35"	\$7,695.00
HDMP3-632	1/4"	40"	\$8,795.00
HDMP3-732	1/4"	50"	\$9,898.00
HDMP3-832	1/4"	60"	\$10,998.00
Bag Stretcher (for all except 20" machines)			\$995.00
Optional 3/8" Wide Seal			\$275.00
FOB: Factory, San Marcos, CA			

- Built-In Features:**
- Digital Operator Interface and PLC Control: Accurate Digital Timers
 - Detachable Seal Bars: Upgradeable to seal lengths up to 60"
 - NEMA 4 Stainless Steel Enclosure: Laser Cut and Welded Seams
 - Upper and Lower Heater elements (Flat) Fast Seal Times Upper/Both Heater Element Toggle Switch
 - High Pressure Seal Jaws
 - Safe, Low Pressure Jaw Close
- Specifications:**
- Seal Length: 20", 25", 30" (Small Body) 35", 40", 50", 60" (Large Body)
 - Seal Width: 1/4"
 - Wide Seal Jaw Opening: 4"

ECONOMY IMPULSE AUTO SEALERS

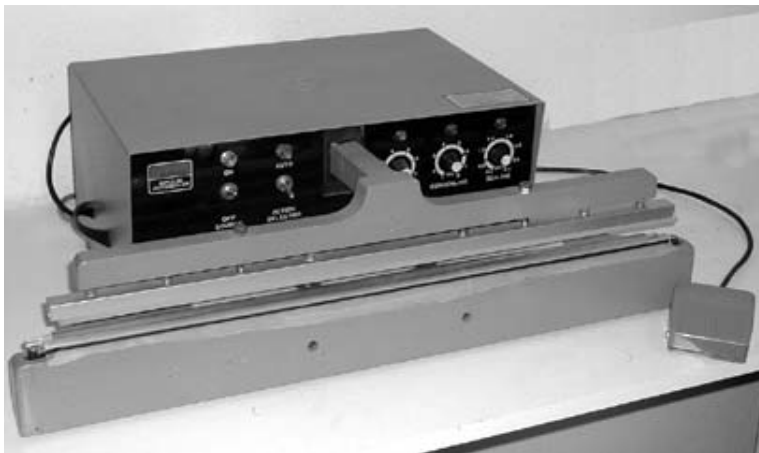

WCA-602 Economy Impulse Auto Sealer.

The **Economy Impulse Auto Sealer** by TEW is Fully Automatic or Foot-Operated. In the Auto Mode, the sealing process is continuously recycled at pre-set time intervals. The time intervals for the cycle are adjustable by the operator. In the Manual Mode, the unit is a table-top semi-automatic impulse sealer operated by an electric footswitch. In both modes, the heat cycle and cooling cycle are automatically controlled by timers that are set by the operator based on job specifications. The units are electromagnetically powered, so no compressed air is needed. Just plug it in to a regular 120 volt wall outlet and you are ready to go.

The Auto-Sealers are equipped with easily replaced elements and a spool-off teflon cover for easy maintenance. Their compact size and light weight makes them portable to go from job to job. They come in seal lengths of 12", 18" or 24" with seal widths of 2mm or 5mm. For production volume of approx. 1000 bags per day.

WCPE Model #	Mfgs Part #	Seal Length	Seal Width	Sealer Price	Spare** Parts Kit	Nichrome Element	Teflon Cover	Teflon Insulator	Silicone Rubber
WCA-302	W-300A	12"	2mm	\$442.50	\$21.00	\$3.00	\$15.00	\$2.50	\$10.00
WCA-305	W-305A	12"	5mm	\$472.50	\$25.00	\$6.00	\$15.00	\$2.50	\$10.00
WCA-452	TISA-452	18"	2mm	\$577.50	\$24.00	\$4.50	\$15.00	\$3.00	\$13.50
WCA-455	TISA-455	18"	5mm	\$622.50	\$29.00	\$9.00	\$15.00	\$3.00	\$13.50
WCA-602	TISA-602	24"	2mm	\$630.00	\$24.50	\$4.50	\$15.00	\$3.50	\$18.00
WCA-605	TISA-605	24"	5mm	\$660.00	\$29.50	\$9.00	\$15.00	\$3.50	\$18.00

** Spare Parts Kit includes 2 seal elements, 1 teflon cover roll, 2 teflon insulators

West Coast Plastics Equipment Inc., 623 S. Hindry Ave., Inglewood, CA 90301 (new address)

CALL TO ORDER 800-392-8569 / 310-215-3186 or FAX 310-642-0468 01/17

Web Page: www.wcpsealers.com E-Mail: sales@westcoastplastics.com





P.A.C. PNEUMATIC IMPULSE SEALERS

HEAVY-DUTY FLOOR STANDING MODELS

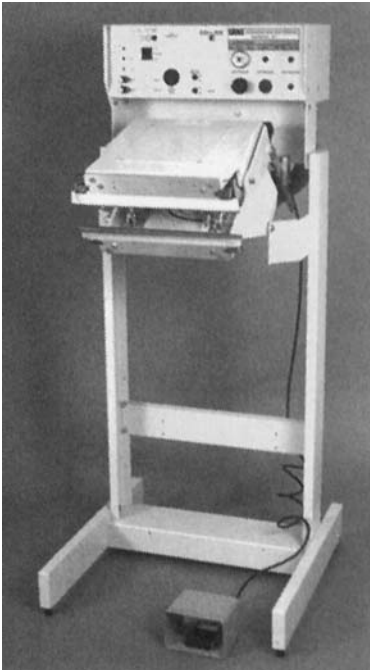

P.A.C. Model PI-G18 Heavy-Duty Pneumatic Impulse Sealer

The P.A.C. PI Pneumatic Impulse Sealer models are heavy-duty, pneumatically operated, floor standing impulse sealers. They come standard with two heated jaws that make a 5/16" wide seal allowing easy sealing of the heavier thermoplastic bags & films. The machine head pivots from completely horizontal to completely vertical to provide sealing capability for a wide variety of applications. The heavy duty machine stand comes standard with rollers for easy maneuverability.

P.A.C. is one of the industry's oldest suppliers of bag sealers with an unequaled reputation for quality sealing machines, so you can count on receiving a quality machine every time. With all these features the P.A.C. PI models are a great value for a small investment.

Model #	Seal Length	Seal Width	Price
PI-G12	12"	5/16"	\$4,895.00
PI-G18	18"	5/16"	\$5,105.00
PI-G24	24"	5/16"	\$5,625.00
PI-G30	30"	5/16"	\$6,130.00
PI-G36	36"	5/16"	\$6,465.00
Options			
Temperature Controller			\$1,960.00
PAC Workshelf			\$623.00
Bag Support for Workshelf			\$257.00
Hot Stamp Printer			\$3,055.00
Characters for Printer			\$15.00
220 Volts			\$257.00
SureSeal Digital interface			\$385.00
Stainless Steel Frame			\$1,835.00
Replacement Parts			
8P09356 Pac Teflon Cover - 10 ft. roll			\$48.00
8P09352A Pac Insulator - 10 ft. roll			\$27.00
2P09355 Pac Element 5/16" x 12"			\$24.55
2P10355 Pac Element 5/16" x 18"			\$29.87
2P11355 Pac Element 5/16" x 24"			\$37.65
2P12355 Pac Element 5/16" x 30"			\$42.86
2P27393 Pac Element 5/16" x 36"			\$46.75
5P09141 Fiberblock Assembly			\$29.20
2A23534 D Washer			\$6.55
FOB: San Rafael, CA			

FEATURES

- Pivoting Head Standard!
- Machine Stand Standard!
- Rollers Standard!
- Top & Bottom Heat Jaws. . . Standard!
- Safety Jaw Close Standard!
- Reliability Standard!

TABLE TOP COMPACT MODELS

The P.A.C. Model PT is a pneumatically operated table-top impulse sealer. With a standard 3/16" wide seal it is ideal for lower production requirements where the heavy-duty P.A.C. Model PI units are not needed. It's compact design and light weight make it ideal for moving from workstation to workstation. Compressed air required, runs on standard 110 volt electrical.

Model #	Seal Length	Seal Width	Price
PT-20	20"	3/16"	\$2,335.00
PT-25	25"	3/16"	\$2,570.00
PT-30	30"	3/16"	\$3,390.00
Bi-Active Seal			\$962.00
Stainless Steel Housing			\$1040.00
Replacement Parts			
8P09311	Pac Teflon Cover - 10 ft. roll		\$48.00
8P09352A	Pac Insulator - 10 ft. roll		\$27.00
2R88519	Pac Element - 20" x 5mm		\$24.55
2R88524	Pac Element - 25" x 5mm		\$29.87
2R88529	Pac Element - 30" x 5mm		\$32.53
FOB: San Rafael, CA.			

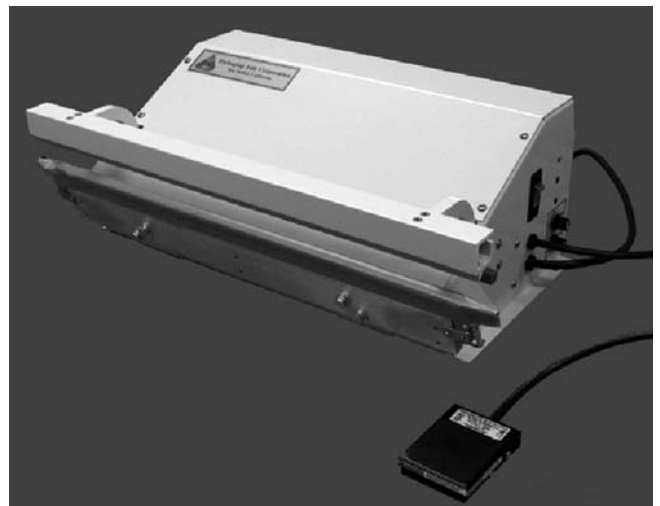

P.A.C. Model PTB-25 Table Top Impulse Sealer.



West Coast Plastics Equipment Inc., 623 S. Hindry Ave., Inglewood, CA 90301 (new address)
 CALL TO ORDER 800-392-8569 / 310-215-3186 or FAX 310-642-0468 01/17
 Web Page: www.wcpsealers.com E-Mail: sales@westcoastplastics.com

VACPACK™ PLEXPACK VACPACK VACUUM SEALER

IP66 MODIFIED ATMOSPHERE PACKAGING



The **Plexpack VacPack IP66** bag sealer is an ideal solution for produce, meat, poultry and seafood packagers who need a high quality, easy to clean, washdown vacuum sealer at a moderate investment. The VacPack packages products at speeds up to 10 bags a minute.

The VacPack uses Venturi style vacuum pump and creates industry leading hermetic seal on any bagging material. The VacPack is also capable of gas flush to create quality modified atmosphere packages. Distinctive advantages of the VacPack are its 1/4" seal width, quality and easy to clean design which provides one touch nozzle tube removal. Additional sanitary design features reduce product contamination of the sealer's venturi pump and solenoids.



VacPack IP66 Vacuum Sealer shown with optional vertical mount crank stand.

Model	Seal Length	Seal Width	Price
VacPack	24"	1/4"	\$11,500.00
Vertical Mount Crank Stand			call
FOB: Toronto, Canada			

VACUUM BAGS - POLY NYLON .003

High quality clear polyethylene and nylon blend vacuum bags. They are complete barrier bags that hold an air tight vacuum to protect products from oxidation, spoilage and corrosion. Okay for food applications. Many sizes in stock with short lead times on the others. Custom Sizes Available - Call for Quote



Size	#/Case	Wt.Case	Price/Cs	Size	#/Case	Wt.Case	Price/Cs	Size	#/Case	Wt.Case	Price/Cs
6 x 8	2M	22	\$101.25	10 x 12	1M	26	\$130.60	14 x 24	500	37	\$144.80
6 x 10	2M	27	\$130.60	10 x 13	1M	29	\$141.45	16 x 20	500	36	\$182.75
6 x 12	2M	32	\$144.50	10 x 15	1M	34	\$161.35	16 x 24	500	43	\$167.80
6 x 15	2M	40	\$155.10	12 x 12	1M	36	\$151.85	16 x 26	250	24	\$113.20
7 x 9	2M	30	\$137.15	12 x 14	1M	37	\$178.40	16 x 28	250	25	\$96.50
7 x 11	2M	33	\$167.60	12 x 16	500	22	\$98.55	18 x 28	250	28	\$108.60
8 x 10	2M	36	\$175.70	12 x 18	500	25	\$101.90	20 x 25	250	29	\$107.75
8 x 12	1M	22	\$82.70	12 x 20	500	27	\$124.95	20 x 28	250	31	\$167.40
8 x 15	1M	27	\$130.60	14 x 16	500	28	\$131.60	22 x 34	250	42	\$161.15
10 x 10	1M	22	\$108.80	14 x 20	500	31	\$120.65	24 x 36	250	50	\$186.15





GRAMATECH GXVS VACUUM SEALERS

The **Gramatech GXVS Pneumatic Vacuum Sealers** feature a heavy-duty stainless steel body and anodized aluminum frame making them perfect for food, medical, clean room and other applications. The 1/4" standard upper & lower heating elements allow heat to enter the material from the top & bottom for better sealing on hard-to-seal materials.

The New PLC Control System has an easy-to-use color touch screen interface for seal, dwell, vacuum and gas flush functions, giving the operator a great deal of flexibility and control to achieve excellent & consistent seals. Three **new standard features** with the PLC Control System models are **single stage gas flush, gas/vac & vac/gas selector, and seal-only mode.**

Gramatech Vacuum sealers come standard with a venturi vacuum pump, a high cost option on many other brands. With no moving or electrical parts the venturi type pump can handle products that give off abrasive residue and products with a high moisture content. With no noisy electric pump motor, the GVS units are very quiet during the vacuum cycle.

The Retractable Nozzle Vacuum System uses two nozzles that extend out in front of the seal bar during loading and vacuum cycle and then retract during the seal cycle. They come in four sizes on the standard body--21",26",31",36", and two sizes in the large body--51" & 61".



Gramatech GXVS-21TS Vacuum Sealer

GRAMATECH GXVS VACUUM SEALERS

Model #	Seal Length	Price
GXVS-21TS	21"	\$5,495.00
GXVS-26TS	26"	\$5,995.00
GXVS-31TS	31"	\$6,495.00
GXVS-36TS	36"	\$6,995.00
GXVS-51TS (large body)	51"	\$10,795.00
GXVS-61TS (large body)	61"	\$11,295.00

OPTIONAL FEATURES

Digital Temperature Control Module	\$3,000.00
3/8" Wide Seal	\$700.00
Stainless Steel Stand	\$895.00
Heavy-Duty Stainless Steel Stand	\$1,700.00
Stainless Steel Shelf for the Stand	\$395.00
Stainless Steel Feeder Tray	\$310.00
4 Nozzles (installed)	\$1,495.00
220-Volt conversion	\$450.00
Clean Room Ready	\$210.00
Spare Parts Kit - varies by model	call
FOB: Commerce, CA	



Mighty Mutt GXMPV-18V Economy Vacuum Sealer

Model #	Seal Length	Price
GXMPV-18V	17.5"	\$2,195.00
GXMPV-18 (seal only-no vacuum)	17.5"	\$1,795.00
Options		
Stainless Steel Workshelf		\$255.00
Built-In Compressor Option		\$1,100.00
Single Stage Gas Flush		\$300.00
Dual Heat Seal System (Top & Bottom Heat)		\$325.00
Spare Parts Kit-GXMPV-18		\$148.20
220 Volt Conversion		\$450.00
Clean Room Ready		\$210.00
FOB: Commerce, CA		

MIGHTY MUTT VACUUM SEALERS

West Coast Plastics offers the **Seco-Gramatech Mighty Mutt GXMPV-18V** table-top vacuum sealer. With a rock-bottom price of \$2,195.00 the Mighty Mutt can't be beat.

The GXMPV-18V comes standard with a retractable nozzle system made of stainless steel for easier packaging and greater sustained vacuum flow. Also standard is the venturi vacuum pump. The GXMPV-18V has been designed with a new PLC control system that has a simple dial operator interface. The unit makes a 1/4" wide, 18" long impulse seal. All painted metal construction will give you many years of good service.

Also available is the **Mighty-Mutt Built-In Compressor Option**. This option adds an internal compressor to the standard GXMPV-18V, so you can just plug it in anywhere you need it without having to have an external compressed air source.



West Coast Plastics Equipment Inc., 623 S. Hindry Ave., Inglewood, CA 90301 (new address)

CALL TO ORDER 800-392-8569 / 310-215-3186 or FAX 310-642-0468 01/17

Web Page: www.wcpsealers.com E-Mail: sales@westcoastplastics.com



P.A.C. PAC-VAC VACUUM SEALERS



PAC Pac-Vac Model PV-G18 shown with optional Workshelf with Bag Support and the optional Bag Stretcher.

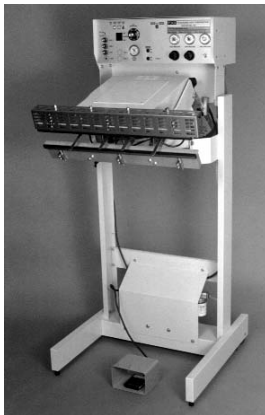

PAC Barrier Vacuum Sealer Model PVB-G24 with optional four nozzles installed.

P.A.C. is one of the industry's oldest suppliers of vacuum sealing machines with an unequalled reputation for quality. The Pac-Vac has been an industry standard for many years. The Pac-Vac comes in many standard and custom configurations to vacuum pack many different types of products.

PVG Series - The standard Pac-Vac Vacuum Impulse Sealer. It features 5/16" wide biactive (top & bottom) seal, analog timer controls, and a 1/4 hp vacuum pump as standard.

PVB Series - The Pac-Vac Vacuum Barrier Sealer with a constantly heated upper jaw that is temperature adjustable to 550°F. The PVB is ideal for vacuum sealing MIL spec barrier bags, coated paper bags, film & foil laminates, and other multi-layer materials. The seal width is 3/4" and a 1/4 hp vacuum pump is standard.

PVS Series - The standard Pac-Vac Vacuum Impulse Sealer except with stainless steel construction. USDA Approved.

Coffee Pac - is a specialty Pac-Vac designed for the coffee industry. The Coffee Pac's extra features include: four stainless steel nozzles and particle ejection system for cleaning the vacuum line. Available as an impulse or barrier sealer (see p. 17).

Fresh Pac - a specialty Pac-Vac uniquely suited to the needs of the food industry, it can be used in both wet and dry environments. Extra features include Venturi vacuum system, NEMA 4X enclosure, larger nozzles, stainless steel construction and USDA Approval (see p. 17).

STANDARD FEATURES

Check out these features that are standard on all Pac-Vac's (but are extra cost options on most other machines!!)

- Gas FlushStandard!
- Pivoting HeadStandard!
- Machine StandStandard!
- RollersStandard!
- Retractable SnorkelsStandard!
- Top & Bottom Heat Jaws (impulse units)Standard!
- Safety Jaw CloseStandard!
- 1/4 Hp Vacuum PumpStandard!

Pac-Vac Spare Parts		
Part#	Description	Price
8P09356	Pac Cover - 10 ft roll	\$48.00
8P09352A	Pac Insulator - 10 ft roll	\$27.00
8P09577	Pac Vacuum Rubber 10 ft roll	\$26.00
5P09141	Fiberblock Assembly	\$29.20
2A23534	D Washer	\$6.55
2P09355	Pac Element 5/16" x 12"	\$24.55
2P10355	Pac Element 5/16" x 18"	\$29.87
2P11355	Pac Element 5/16" x 24"	\$37.65
2P12355	Pac Element 5/16" x 30"	\$42.86
2P27393	Pac Element 5/16" x 36"	\$46.75

P.A.C. Pac-Vac Vacuum Sealers				
Model No.	Type	Seal Length	Seal Width	Price
PV-G12	Impulse	12"	5/16"	\$7,475.00
PV-G18	Impulse	18"	5/16"	\$7,670.00
PV-G24	Impulse	24"	5/16"	\$8,210.00
PV-G30	Impulse	30"	5/16"	\$8,620.00
PV-G36	Impulse	36"	5/16"	\$8,995.00
Coffee Pac	Impulse/Venturi	18"	5/16"	\$12,695.00
PVS-GA12	Impulse/St. Steel	12"	5/16"	\$9,310.00
PVS-GA18	Impulse/St. Steel	18"	5/16"	\$9,510.00
PVS-GA24	Impulse/St. Steel	24"	5/16"	\$10,050.00
PVS-GA30	Impulse/St. Steel	30"	5/16"	\$10,460.00
PVS-GA36	Impulse/St. Steel	36"	5/16"	\$10,835.00
Fresh Pac	Impulse/Venturi/SS	18"	5/16"	\$12,950.00
PVB-G12	Barrier	12"	3/4"	\$8,255.00
PVB-G18	Barrier	18"	3/4"	\$8,495.00
PVB-G24	Barrier	24"	3/4"	\$9,105.00
PVB-G30	Barrier	30"	3/4"	\$9,360.00
Coffee Pac	Barrier/Venturi	18"	3/4"	\$12,695.00

OPTIONS:

Workshelf - single head	\$623.00
Bag Support for Workshelf - single head	\$257.00
Venturi Vacuum Pump - Type 60 - installed	\$650.00
Hot Stamp Printer for 3/16" characters	\$3,055.00
3/16" High Characters	\$15.00/each
SureSeal Digital Interface	\$385.00
Bag Stretcher	\$930.00
Locking Swivel Casters	\$305.00

FOB: San Rafael, CA

West Coast Plastics Equipment Inc., 623 S. Hindry Ave., Inglewood, CA 90301 (new address)

CALL TO ORDER 800-392-8569 / 310-215-3186 or FAX 310-642-0468 01/17

Web Page: www.wcpsealers.com E-Mail: sales@westcoastplastics.com





P.A.C. TABLE TOP VACUUM SEALERS

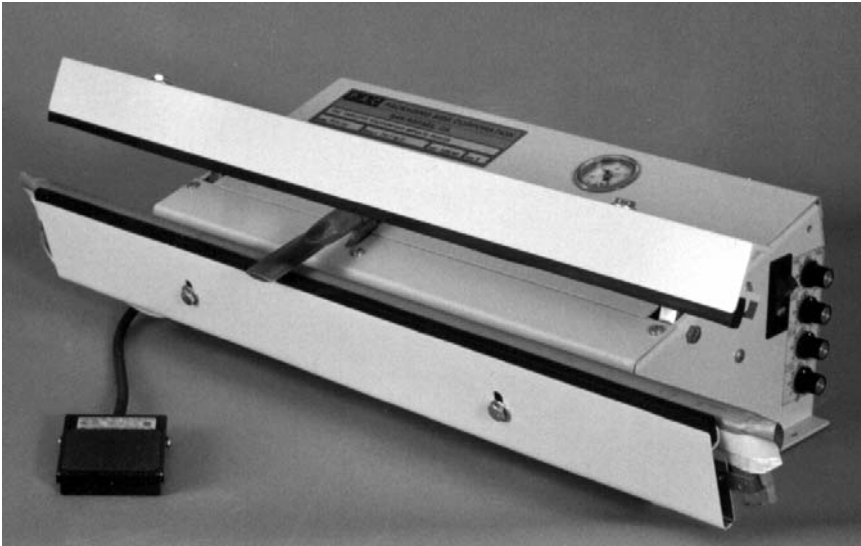

P.A.C. Model PVTB-25 Table Top Vacuum Sealer

The **PAC Model PVT Table Top Vacuum Impulse Sealer** is a compact, heavy-duty, pneumatically operated sealer with a venturi-type vacuum system. The machine has a single heated jaw and **large retractable nozzle**.

Options designed to facilitate your packaging operations can include gas flush capabilities, higher voltages, work shelf, stand and others. The standard seal width is 3/16", compressed air needed at 90PSIG.

"Seal Only" Model PT pneumatic impulse sealers are also available without the vacuum system for your sealing applications that do not require it (see page 10).

For those heavy-duty applications, such as E.S.D. barrier bags, PAC offers the **Coffee Pac Lite**. The Coffee Pac Lite has top & bottom heated jaws which makes it able to seal very heavy duty materials such as E.S.D. barrier bags, foils, papers, etc. The two large retractable nozzles allow for extremely quick vacuum cycles and the capacity to do two smaller bags at once. Gas flush and auto-purge are both standard. All these features in a small package makes the Coffee Pac Lite a real **value** that will get your job done!



P.A.C. Coffee Pac Lite 20A

P.A.C. Table Top Vacuum Sealers		
Model No.	Seal Length	Price
PVT-20	20"	\$4,245.00
PVT-25	25"	\$4,555.00
PVT-30	30"	\$5,225.00
Coffee Pac Lite 20A	20"	\$6,020.00
Coffee Pac Lite 25A	25"	\$6,475.00
Options:		
Gas Flush		\$595.00
Bi-Active Seal (top & bottom heat)		\$965.00
220 Volt Electrical		\$705.00
Spare Parts:		
8P09311	Pac Teflon Cover - 10 ft roll	\$48.00
8P09352	Pac Insulator - 10 ft roll	\$27.00
8P09577	Pac Vacuum Rubber - 10 ft roll	\$26.00
5P09141	Pac Fiberblock Assembly	\$29.20
2A23534	Pac D Washer	\$6.55
2R88519	Pac Element 20" x 5mm	\$24.55
2R88524	Pac Element 25" x 5mm	\$29.87
2R88529	Pac Element 30" x 5mm	\$32.53
8R40513	Pac Sealing Wire - 3/16" x 10 ft roll	\$14.10
8R40704	Pac Seal Rubber - 10 ft roll	\$57.00
Dow#7	Silicone Grease - 5.3 oz tube	\$15.00
FOB: San Rafael, CA		





ACCU-SEAL 675 VACUUM SEALERS



Accu-Seal Model 675V-25-3

The economical **Accu-Seal "SmartVAC" Vacuum Bag Sealer** is designed and built in the USA using the highest quality components and materials to provide unmatched product quality and trouble free performance at a great price. Built tough to handle any production environment and with user friendly controls that operators can learn in minutes. They also have open ended seal bars and a retractable vacuum nozzle for production speed. It is loaded with many standard features including an emergency stop switch. The SmartVAC is designed for use on a table top or on a machine stand and is available with an optional product support tray.

Three Models - To offer the best possible pricing and delivery, Accu-Seal designed three models in the SmartVAC Series. You can easily select the machine with the features you need and not have to pay for those you don't. Selectable sealing modes by model:

SmartVAC Model 1 - Vacuum Sealer

- Vacuum-Seal cycles
- Seal only cycle

SmartVAC Model 2 - Gas-Vac Sealer

- Vacuum-Seal cycles
- Gas-Vacuum-Seal cycles
- Seal only cycle

SmartVAC Model 3-Gas-Vac w/Multiple Operating Modes

- Vacuum-Seal cycles
- Gas-Vacuum-Seal cycles
- Vacuum-Gas-Seal cycles
- Vac1-Gas1 (1-99) + Vac2-Seal cycles
- Gas1-Vac1 (1-99) + Gas2-Seal cycles
- Seal only cycle

SmartVAC Model 1 - Vacuum Sealer					
Model No.	Seal Width	Seal Length	Size LxWxH	Ship Wt.	Price
675V-20-3	1/4"	20"	24 x 16 x 9	52	\$4,375
675V-25-3	1/4"	25"	29 x 16 x 9	54	\$4,675
675V-30-3	1/4"	30"	34 x 16 x 9	56	\$5,195
SmartVAC Model 2 - Gas-Vac Sealer					
675G-20-3	1/4"	20"	24 x 16 x 9	52	\$4,775
675G-25-3	1/4"	25"	29 x 16 x 9	54	\$4,975
675G-30-3	1/4"	30"	34 x 16 x 9	56	\$5,545
SmartVAC Model 3-Gas-Vac w/Multiple Operating Modes					
675M-20-3	1/4"	20"	24 x 16 x 9	52	\$5,295
675M-25-3	1/4"	25"	29 x 16 x 9	54	\$5,795
675M-30-3	1/4"	30"	34 x 16 x 9	56	\$6,295
Options					
816-0025 Machine Stand (all sizes)					\$940
511-0045 Support Tray (all sizes)					\$109
620-0030 Moisture/Particle Vacuum Filter-1/4"					\$220
FOB: San Marcos, California.					



ACCU-SEAL BUDGET VACUUM SEALERS



Accu-Seal Model 235-232

The **Accu-Seal Model 235 Budget Vacuum Sealer** is designed for the user who just needs a basic vacuum sealer, this member of the Accu-Seal vacuum sealer family simplifies the process and cuts the cost of high-quality vacuum sealing.

Features include heat & cool timers, electronic foot switch activation, retracting nozzle, thermal overload protection, exhaust silencer, non-particle generating vacuum pump. The length of the vacuum cycle is controlled by the user. Hold the electronic foot switch down until the desired vacuum is achieved, then let off and the machine activates the heat seal and cool cycles automatically. The seal jaw opens when the bag is done.

One-Year Factory Warranty.

Model #	Seal Width	Seal Length	Size LxWxH	Ship Wt.	Price
235-222	1/8"	20"	26 x 10 x 9	35	\$1,995
235-232	1/4"	20"	26 x 10 x 9	35	\$2,232
620-0030 Moisture/Particle Vacuum Filter-1/4"					\$220
816-0002 Machine Stand - 20"					\$940
511-0008 Support Tray - 20"					\$95

Need Vacuum Bags?

See page 11





ACCU-SEAL HDMP3 VACUUM SEALERS

The New **Accu-Seal HDMP3 Series Accu-Sealer** has the power and control it takes to handle virtually any sealing application. Tough, it can withstand the harshest environments: hot wash down, sterilization fluids, cold rooms, or clean rooms. Easy disassembly of external component parts allows immersion for complete cleaning.

Thick, thin, gusseted, laminated, paper, plastic, flat or dual-sided bags are no longer a challenge for one machine to handle. You can select dual side or single side heating. High-pressure seal bars give these machines the perfect seal every time. The new wider 4" open-end jaw design will enable end-to-end feed through of the bag material.

Features:

- Digital Operator Interface & PLC Control
- Detachable Seal Bars - easy to clean & maintain
- NEMA 4 Stainless Steel Enclosure
- US Manufactured Pneumatics
- Upper & Lower Heater Elements
- Upper/Both Heater Element Toggle Switch
- Gas Purge Standard
- High-Flow Retracting Vacuum Nozzles
- High Pressure Seal Jaws with 4" wide opening
- Low Pressure Safety Jaw Close
- New Extended Element Life Design
- 2-Year Limited Factory Warranty
- Seal Lengths Available 20" to 60"
- Seal Elements Available: 1/8", 1/4", 3/8", 1/2" (flat), Beaded Band, T-Profile



Model	Seal Width	Seal Length	Vacuum Nozzles	Price
HDMP3-232GV	1/4"	20"	2	\$8,795
HDMP3-332GV	1/4"	25"	2	\$9,195
HDMP3-432GV	1/4"	30"	2	\$9,495
HDMP3-532GV	1/4"	35"	4	\$10,995
HDMP3-632GV	1/4"	40"	4	\$11,920
HDMP3-732GV	1/4"	50"	4	\$12,895
HDMP3-832GV	1/4"	60"	4	\$13,820
Options				
Bag Stretcher				\$995
108-0003 Ultra Quiet Lab Compressor				\$2,095
816-0010 Machine Stand for Small HDMP (20"-30")				\$1,095
816-0011 Machine Stand for Large HDMP (35"-60")				\$1,155
602-0020 Moisture/Particle Vacuum Filter-Small HDMP(20"-30")				\$220
602-0022 Moisture/Particle Vacuum Filter-Large HDMP(35"-60")				\$440
FOB: San Marcos, CA.				

ACCU-SEAL ERGONOMIC MACHINE STAND

Accu-Seal's Ergonomic Multi-Position Machine Stand is the perfect stand for many Accu-Seal vacuum and heat sealers. Its light, sturdy frame is adjustable by one operator to meet the proper height and machine angles to insure the maximum productivity. The rigid modular design allows the Sealer to rotate 180 degrees (from vertical up to vertical down), with locking casters for easy mobility. Dual hand wheels allow quick access to full rotation and 6" elevation change (standard height set for 5'1" to 6'2" operators).



Machine Stand (shown with Model 635 Vacuum Sealer)

Part Number	Description	Price
816-0001	Stand for Accu-Seal Sealers with 15" Seal Length	\$940.00
816-0002	Stand for Accu-Seal Sealers with 20" Seal Length	\$940.00
816-0003	Stand for Accu-Seal Sealers with 25" Seal Length	\$940.00
816-0004	Stand for Accu-Seal Sealers with 30" Seal Length	\$1,013.00
816-0005	Stand for Accu-Seal Sealers with 35" Seal Length	\$1,013.00
816-0010	Stand for HDMP Sealers with 20,25,30" Seal Lengths	\$1,095.00
816-0011	Stand for HDMP Sealers with 35,40,50,60" Seal Lengths	\$1,155.00
816-0012	Full Vertical Stand for HDMP Sealers with 20,25,30" Seal Lengths	\$1,170.00
816-0013	Full Vertical Stand for HDMP Sealers with 35,40,50,60" Seal Lengths	\$1,250.00
816-0025	Stand for Accu-Seal Smart-Vac Series 675 (all sizes)	\$940.00
FOB: San Marcos, CA.		



West Coast Plastics Equipment Inc., 623 S. Hindry Ave., Inglewood, CA 90301 (new address)

CALL TO ORDER 800-392-8569 / 310-215-3186 or FAX 310-642-0468 01/17

Web Page: www.wcpsealers.com E-Mail: sales@westcoastplastics.com



P.A.C. SPECIALTY VACUUM SEALERS

P.A.C. Coffee Pac - Vacuum / Gas Flush Sealer



Coffee Pac - Barrier

The **Packaging Aids Corp. Coffee PAC Vacuum/Gas Sealer** provides roasters and packagers an efficient and economical method of preserving the freshness of their product. The Coffee Pac has four stainless steel nozzles for production efficiency. Four standard bags or two larger ones can be vacuumed during each cycle. The Coffee Pac packages approximately 4 cycles per minute or 16 bags can be produced depending upon operator efficiency. Additional nozzles can be added on request. The Coffee Pac vacuum system has four high-flow Venturi vacuum pumps, one for each nozzle. Quiet and powerful, the Venturi allows the coffee particles to pass through without damaging the pump. The Coffee Pac comes standard with an air-flush system to clear the vacuum lines of any coffee debris after every vacuum cycle.

The Coffee Pac can back flush the bag with any desired gas. The flushing sequence can easily be changed from vacuum then gas, to gas then vacuum, or gas only with no vacuum. All Packaging Aids machines for the coffee industry are supplied with biactive seal bars (top & bottom heat) to provide the utmost in security when sealing all types of plastic and foil bags. It can be ordered with either an impulse seal system or with a constant heat "barrier" bag seal system.

P.A.C. Fresh Pac - Vacuum / Gas Flush Sealer



Fresh Pac

The **Packaging Aids Corp. Fresh PAC Vacuum/Gas Sealer** is uniquely suited to the needs of the fresh food industry as it can be used in both wet and dry environments. This USDA approved stainless steel sealing machine is designed for vacuum and/or modified atmosphere packaging (MAP) of fresh foods such as produce, meat, poultry, nuts, baked goods, spices and pasta.

There are many features that make the Fresh Pac ideal for fresh food packaging. Wide stainless steel profiled nozzles facilitate faster air removal and allow easy entry into and out of bags. The Cleaning System is valuable when using wet products. The Cleaning System includes easily removable nozzles, special pass through Venturi vacuum pumps and food trap with automatic evacuation at end of each cycle. The vacuum line can be back flushed with chlorine or other cleaning agent (optional). The electronic controls for vacuum, seal and cool are mounted in a Nema 4X watertight enclosure above the seal head. A pneumatically controlled and watertight foot switch allows operator to initiate the vacuum cycle. The Fresh Pac has a stainless steel frame for washdown capability with rear wheels for easy station-to-station mobility. The sealing head is adjustable with three position height adjustment, as well as movement from a horizontal to a vertical position, for more convenient ergonomic operation.

P.A.C. PVK Bag-In-Box Vacuum / Gas Flush Sealer



Bag-In-Box

The **Packaging Aids Corp.** heavy duty, high production, **PVK Bag-In-Box** industrial impulse vacuum sealer may be used for vacuum and/or gas purge applications, including those requiring modified atmosphere packaging (MAP). With its "open head design" for fast and easy bag loading, the PVK industrial vacuum sealer delivers both speed and flexibility for high volume packaging applications. This vacuum sealer is designed for heavy bags (25lbs and up) that are used as a box liner, where the box comes under the sealer via a conveyor or support. The machine's open-head design provides easy access to bag positioning.

Model	Seal	Dimensions	Price
Coffee Pac - Impulse	18" x 5/16"	26"W x 27"D x 57"H	\$12,695.00
Coffee Pac - Barrier	18" x 1/2"	26"w x 27"D x 57"H	\$12,695.00
Fresh Pac - Impulse	18" x 5/16"	28"W x 32"D x 70"H	\$12,950.00
PVK-30-BIB	30" x 5/16"	33"W x 38"D x 75"H	\$26,295.00
PVK-36-BIB	36" x 5/16"	39"W x 38"D x 75"H	\$27,010.00
PVK-42-BIB	42" x 5/16"	45"W x 38"D x 75"H	\$28,045.00
PKV-48-BIB	48" x 5/16"	51"W x 38"D x 75"H	\$29,045.00
FOB: San Rafael, CA.			





AUDION-VAC VACUUM CHAMBER SEALERS



The Audion-Vac Series of Vacuum Chamber Sealers



Audion VMS43 Vacuum Chamber

The **Audion Vacuum Chambers** are of the latest design and engineering. With its compact construction, stainless steel frame & chamber and high strength transparent lid, the Audion Chamber is U.S.D.A. approved. All models except the VMS43 & VMS53 are computer controlled with electronic digital displays. The electronic board is designed to operate in an adverse environment. The board can easily be setup with up to nine different programmed settings for individual applications. With just a touch of a button the setting can be changed when the job changes. The VMS43 & VMS53 have analog controls for the seal & vacuum cycles. In addition each sealbar on the Audion Vacuum Chamber features dual side-by-side 1/8" wide seals.

Seven table top models are available--VMS43, VMS53, VMS153, CV151, CV152, CV162 & VMS163. There are two single chamber floor models--CV230 & CV330. The CV152, CV162, VMS163BG and the two single chamber floor models have two sealbars in the chamber, effectively doubling their productivity. The CV520, CV540 & CV550 are the double chamber floor units, one chamber can be loaded while the other is cycling, greatly improving productivity. Each double chamber has four sealbars, two in each chamber. In addition, the double chambers are equipped with a pneumatic lid that automatically opens and closes, to maximize operator efficiency. The high vacuum/capacity pumps are extremely effective and efficient in packaging. The reduction of atmosphere averages 98% on most applications. Another special feature of the Audion-Vac is soft air return, which is designed to protect delicate products.

Options available on most Audion-Vac Vacuum Chambers include: gas flush cycle, vacuum level sensor, biactive seal bars, multi-cycle capability--call for more information.

	Chamber Size	Chamber Depth	Seal Bar	Vacuum	Electrical	Price
Table Top Models						
VMS43	10.5" x 12.25"	3.25"	10.5" (1)	2.5 CFM	115V	\$2,460.00
VMS53	10.5" x 12.25"	4.75"	10.5" (1)	5.0 CFM	115V	\$2,830.00
VMS153	16.25" x 14.5"	6.5"	16.25" (1)	12.5 CFM	115V	\$4,780.00
CV151	17.1" x 16.5"	6.7"	16.5" (1)	1.25 Hp	115V	\$3,715.00
CV152	17.1" x 16.5"	6.7"	16.5" (2)	1.25 Hp	115V	\$4,145.00
CV162	23.6" x 14.8"	5.3"	14.2" (2)	1.25 Hp	115V	\$4,345.00
VMS163	16.25" x 18"	6.5"	16.25" (2)	12.5 CFM	115V	\$6,115.00
Single Chamber Floor Models						
CV230	28.7" x 21.6"	6.1"	19.7" or 26.8" (2)	3 Hp	220V 3-ph	\$9,440.00
CV330	33" x 21.9"	7.0"	20.4" or 31.5" (2)	3 Hp	220V 3-ph	\$10,570.00
Double Chamber Floor Models						
CV520	32.9" x 21.6" (2)	7"	26.8" (4)	3 Hp	220V 3-ph	\$15,715.00
CV540	42.7" x 35.8" (2)	9.8"	35.4" (4)	10 Hp	220V 3-ph	\$26,115.00
CV550	49" x 40" (2)	9.8"	43.3" (4)	15 Hp	220V 3-ph	\$32,965.00
FOB: San Rafael, CA.						



West Coast Plastics Equipment Inc., 623 S. Hindry Ave., Inglewood, CA 90301 (new address)
CALL TO ORDER 800-392-8569 / 310-215-3186 or FAX 310-642-0468 01/17
Web Page: www.wcpsealers.com E-Mail: sales@westcoastplastics.com

PROMARKS VACUUM CHAMBERS

Table-Top Single Chamber Models

The Promarks Vacuum Chamber table-top bag sealers are ideal for limited spaces. Economic and professional, they have stainless-steel construction and a clear see through lid. All units feature a computerized water resistant control panel which has an oil indicator and 20 program memory. The "F" models (TC-280F, TC-420F and TC-520F) have one sealbar along the front of the chamber. The "LR" models (TC-420LR and TC-520LR) have two sealbars, one on the left side of the chamber and one on the right side. All sealbars can be ordered with either impulse seal or electric cut-off seal (specify at time of order.) Also standard is a vacuum pump and 115 VAC power operation. Extra cost options include gas flush, sensor control, 220 VAC 1-phase electrical, and bi-active sealing. One Year Factory Limited Warranty. UL, CSA & NSF Approved.

Model No.	Chamber Size	Seal Length	Pump	Price
TC-280F	14.1" x 15.1" x 3.7"	11.8" (one)	0.50 hp	\$2,095
TC-420F	19.8" x 19.2" x 3-4"	17.7" (one)	1.25 hp	\$3,470
TC-420LR	19.8" x 19.2" x 3-4"	16.9" (two 14.5" apart)	1.25 hp	\$3,770
TC-520F	23.6" x 23.6" x 3-4"	21.2" (one)	1.25 hp	\$4,770
TC-520LR	23.6" x 23.6" x 3-4"	21.2" (two 17.7" apart)	1.25 hp	\$5,395

FOB: Rancho Cucamonga, CA



Promarks TC-280F-6 Table Top Chamber Vacuum Sealer

Floor Single Chamber Models

The Promarks Single Chamber Floor Model Vacuum Sealers are mounted on wheels and are designed and built for industry. They have stainless-steel construction and a flat chamber for easy cleaning. All units feature a computerized water resistant control panel which has an oil indicator and 20 program memory. They have a dome-style lid. Each unit has two twin impulse seal bars, air assist and a Busch vacuum pump. All sealbars can be ordered with either impulse seal or electric cut-off seal (specify at time of order.) Smaller units (SC-420LR and SC-520LR) come standard with 110 VAC, 1-phase electrical. Larger units (SC-680LR and SC-800LR) come standard with 230 VAC 3-phase electrical. Extra cost options include gas flush, sensor control, pump size, bi-active seal, soft air exhaust. One Year Factory Limited Warranty. UL, CSA & NSF Approved.



Promarks Series SC Single Chamber Vacuum Sealer

Model No.	Chamber Size	Seal Length	Pump	Price
SC-420LR	19.8" x 19.2" x 3-4"	16.9" (two 14.5" apart)	1.25 hp	\$4,570
SC-520LR	23.6" x 23.6" x 3-4"	21.2" (two 17.7" apart)	1.25 hp	\$5,570
SC-680LR	33.8" x 23.6" x 7"	20.5" (two 26.3" apart)	2.00 hp	\$6,995
SC-800LR	36.2" x 29.1" x 8"	26.0" (two 28.7" apart)	3.00 hp	\$9,995

Double Chamber Models

Very popular, the Promarks Double Chamber Vacuum Sealers offer many great features including stainless steel construction, flat chamber for easy cleaning, computerized water resistant control panel which has an oil indicator and 20 program memory, water resistant electrical box, pump overload warning indicator, oil change indicator, heavy duty casters, air assist, dome style lid. Each unit has two twin impulse seal bars in each chamber with 10mm wide seals. All units feature Busch vacuum pumps for reliable, strong vacuum of the chamber. Also standard is 230 VAC, 3-phase power operation. Extra cost options include gas flush, sensor control, bi-active sealing, custom chamber height, custom voltage, auto lid transfer-call for more info. One Year Factory Limited Warranty. UL, CSA & NSF Approved.

Model No.	Chamber Size	Seal Length	Pump	Price
DC-530	30" x 23.6" x 7"(2)	21.2" (four 16.8" apart)	2.00 hp	\$9,980
DC-640	32" x 29" x 8"(2)	25.2" (four 22" apart)	3.00 hp	\$12,880
DC-650	32" x 35" x 8"(2)	25.2" (four 28" apart)	5.00 hp	\$13,880
DC-800	38.5" x 31" x 8"(2)	31.5" (four 24" apart)	5.00 hp	\$14,985
DC-860	40.9" x 40.7" x 10"(2)	34.6" (four 33" apart)	12.00 hp	\$19,990
DC-900	48" x 41" x 12"(2)	39.3" (four 34.6" apart)	12.00 hp	\$24,990



Promarks Series DC Double Chamber Vacuum Sealer

West Coast Plastics Equipment Inc., 623 S. Hindry Ave., Inglewood, CA 90301 (new address)

CALL TO ORDER 800-392-8569 / 310-215-3186 or FAX 310-642-0468 01/17

Web Page: www.wcpsealers.com E-Mail: sales@westcoastplastics.com





SIPROMAC VACUUM CHAMBERS

Table-Top Single Chamber Models

Economic and professional, Sipromac Chambers have stainless-steel construction and are USDA approved. The Model 300, 300D, 350, 350D, 380 & 380T have a see through lid, the Model 450T has dome-style lid. The 300, 300D, 350, 350D & 450T have 19" long sealbars. The 380 has two 12.5" sealbars. The 380T has two 12.5" side sealbars and one 32.2" front sealbar. All units except the Model 300s feature the MC40 Microprocessor Control which has a vacuum sensor and 20 program memory. The 300 and 300D have dial controls for vacuum and seal cycles. Also standard is a 1.25HP vacuum pump and 115 VAC power operation. Extra cost options include gas flush, air regulator, stainless steel cart, and soft air exhaust. One Year Factory Limited Warranty.

Model No.	Chamber Size	Seal Length	Ship Wt.	Price
250	15" x 14" x 4"	12.5"(one)	200 lbs.	\$3,745
300	20" x 20" x 7"	19.1" (one)	242 lbs.	\$4,170
300D	20" x 20" x 7"	19.1" (two)	242 lbs.	\$4,460
350	20" x 20" x 6.5"	19.1" (one)	242 lbs.	\$4,520
350D	20" x 20" x 6.5"	19.1" (two 13" apart)	242 lbs.	\$4,885
380	40" x 14" x 5"	12.5" (two 36" apart)	350 lbs.	\$6,410
380T	40" x 14" x 5"	12.5" (two) & 32.2" (one)	350 lbs	\$6,805
450T	27.5" x 20" x 8"	19.5" (two 22" apart)	327 lbs.	\$6,635

FOB: Quebec, Canada



Sipromac Model 350

Floor Single Chamber Models

These large and robust single chamber floor model machines are mounted on wheels and are designed and built for industry. They have stainless-steel construction and are USDA approved. They have a dome-style lid. Each unit has two twin impulse seal bars. All units feature the MC40 Microprocessor Control which has a vacuum sensor and 20 program memory except the Model 400 which has dial controls for the vacuum and seal cycles. Also standard is 208-240 VAC, 3-phase power operation. Extra cost options include gas flush, air regulator, electric cut-off wire, soft air exhaust. One Year Factory Limited Warranty.

Sipromac Model 450-A



Model No.	Chamber Size	Seal Length	Ship Wt.	Price
400	27.5" x 20" x 9.5"	19.5" (two 23" apart)	460 lbs.	\$7,060
450-A	27.5" x 20" x 9.5"	19.5" (two 23" apart)	460 lbs.	\$8,120
550-A	28" x 28" x 8"	25.25" (two 23" apart)	625 lbs.	\$10,070
580-A	42.5" x 37.5" x 8"	33.5" (two 36" apart)	call	\$14,305

FOB: Quebec, Canada

Double Chamber Models

Very popular throughout the world, these industrial machines offer the best features available including the MC40 Microprocessor Control which has a vacuum sensor and 20 program memory. They have stainless-steel construction and are USDA approved. The double chamber configuration allows for double the production--one chamber can be loaded, while the other chamber is going through the vacuum seal cycle. Each unit has two twin impulse seal bars in each chamber. Also standard is 208-240 VAC, 3-phase power operation. The Model 680A features automatic cover movement, vacuum sensor and air regulator. Extra cost options include gas flush, air regulator, electric cut-off wire, soft air exhaust. One Year Factory Limited Warranty.

Model No.	Chamber Size	Seal Length	Ship Wt.	Price
420-A	27" x 24" x 8"	17" (four 17.5" apart)	642 lbs.	\$9,780
600-A	35" x 30" x 8"	25.25" (four 22.5" apart)	902 lbs.	\$13,880
620-A	34" x 32" x 8"	26" (four 28" apart)	1160 lbs.	\$14,280
650-A	43" x 38.5" x 8"	33.5" (four 31" apart)	1580 lbs.	\$17,600

FOB: Quebec, Canada



Sipromac Model 600-A Double Chamber Vacuum Sealer



West Coast Plastics Equipment Inc., 623 S. Hindry Ave., Inglewood, CA 90301 (new address)

CALL TO ORDER 800-392-8569 / 310-215-3186 or FAX 310-642-0468 01/17

Web Page: www.wcpsealers.com E-Mail: sales@westcoastplastics.com

EMPLEX MPS 7103 & 7503

HEAVY-DUTY BAND SEALER WITH VACUUM/GAS FLUSH SYSTEM

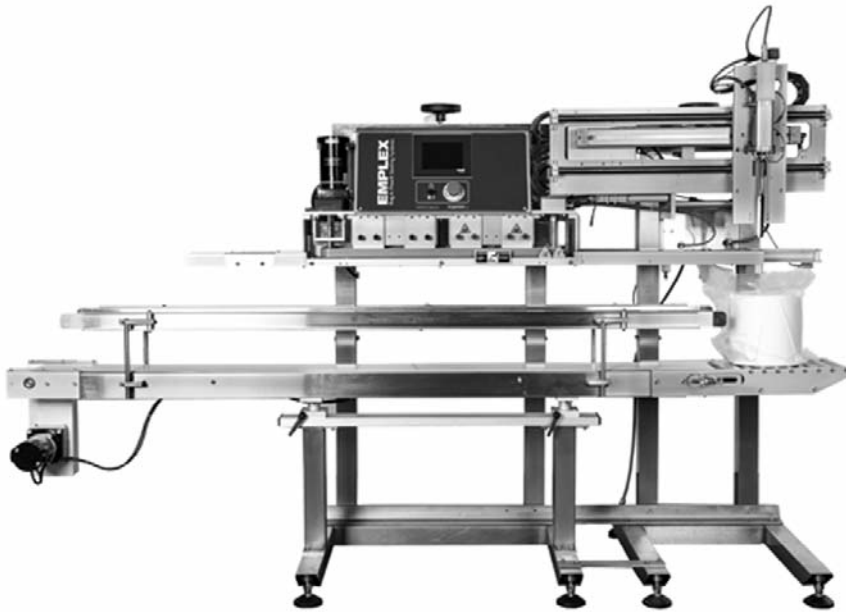

Emplex MPS-7503 Dual-Heat Band Sealer with Vacuum/Gas Flush System and Integrated Product Conveyor

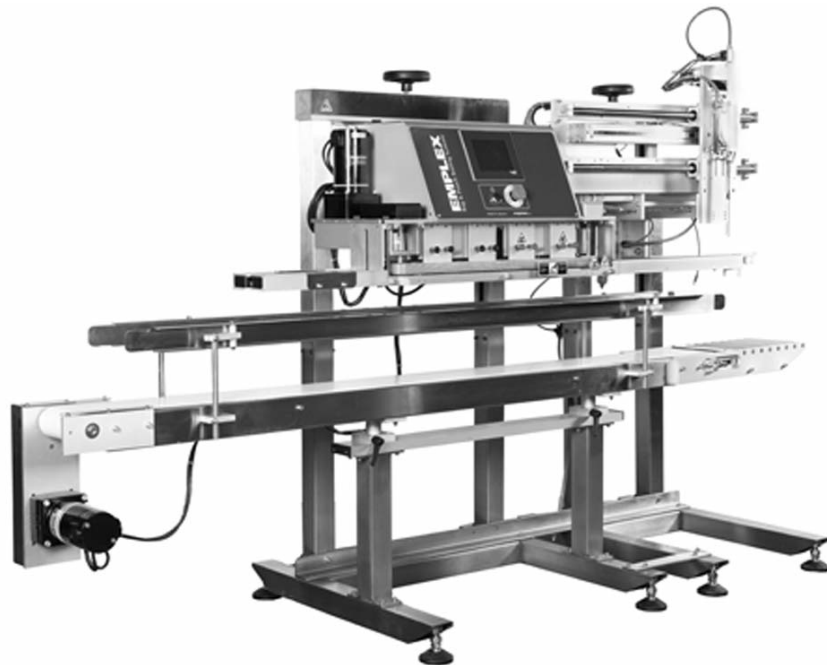

Emplex MPS-7503 Dual-Heat Band Sealer with Vacuum/Gas Flush System and Integrated Product Conveyor

The **Emplex MPS 7103 & 7503** are new high speed, continuous band sealer equipped with a vacuum and/or nitrogen gas flush system. The MPS 7103 & 7503 create high quality moisture proof, oxygen free packages. It is ideal for customers that require higher capacity output than our impulse vacuum sealer.

Typically, customers requiring more than 3 bags a minute find a greater return on investment by choosing a continuous band vacuum sealer. Satisfied customers include producers of coffee, snacks, pre-baked goods, electronics, medical products, meat, produce and fresh & dried foods.

The MPS 7503 includes a synchronized conveyor for a more automated system and to support bags weighing 2 pounds or more. The MPS 7103 is able to support bags weighing up to 2 pounds in the infeed belts. The conveyor ensures easy, consistent handling and product orientation as bags enter and exit the sealer. The MPS 7503 provides high quality, hermetic seals on all moisture-barrier bag materials and is capable of sealing bags up to 12 mil in thickness or 6 mil maximum when gusseted at required production speeds.

The vacuum and/or nitrogen gas flush system removes oxygen resulting in longer shelf life, product integrity, and protection against discoloration. For snack products, a gas flush only system can create a cushion-like buffer against damage.

All of the Emplex MPS 7000 Series bag sealers are equipped with the new PLC control system and touch screen operator interface. They can also be equipped with IP-66 washdown electrics, bag top trimmer, emboss coder, dry ink printer, or ink jet printer. Designed for 24/7 operation, these sealers are suitable for all production environments.

Technical Specifications

Electrical: 120VAC, 60Hz, 1350W, 12A

Air Supply: 40CFM @ 80PSI

Speed: Variable to 750 inches per minute

Temperature Range: 150 to 450F

Seal Width: 1/4" Standard (other sizes available)

Vertical Adjustment: 29.5" - 43" (750-1100mm)

Control System: PLC with Touch Screen Interface

**For More Options
See Page 26**

Model #	Description	Price
MPS7103	Heavy Duty Band Sealer With Vacuum/Gas Flush System	\$25,620
MPS7503	Heavy Duty Band Sealer With Vacuum/Gas Flush System and Conveyor	\$28,765
	Optional Infeed Roller Bed for Conveyor	\$735
FOB: Ontario, Canada		

West Coast Plastics Equipment Inc., 623 S. Hindry Ave., Inglewood, CA 90301 (new address)

CALL TO ORDER 800-392-8569 / 310-215-3186 or FAX 310-642-0468 01/17

Web Page: www.wcpsealers.com E-Mail: sales@westcoastplastics.com



EMPLEX MPS6100 BAND SEALERS

The **Emplex MPS6100 Series Basic Band Sealers** boast a wide range of standard features and capabilities. These continuous feed sealers have a standard control panel with the new PLC control system with touch screen HMI interface for programming and monitoring your sealer performance. The MPS6100 Series utilizes variable pressure sealing bars for the sealing process which accommodate for variation in bag thickness or composition, ensuring a hermetic seal every time. All seals are created using economical etched Teflon bands which maintain high seal quality and produce consistently strong, clean seals on all heat sealable bags.

Add-On Versatility

A number of add-on options modify and enhance the sealing functionality of this series. These options include: trimmers, printers, embossers, conveyors, perforation units and more. This add-on principle means you can add-on any of these options at any time to the sealing unit, even after the purchase. Most take just a few bolts to add-on. See page 26 for more information on the options.

Minimized Seal to Product Distance

MPS Series machines reduce empty space found between the product and seal to its smallest physical limit, thereby reducing bag wastage, increasing shipping volume, and enhancing product appearance.

Strong Support Capability

Emplex's exclusive infeed system is capable of supporting significant bag weights without the use of a conveyor. Typically, the MPS6100 can support a 10" wide bag containing 2 pounds of product. More weight can be supported with wider bags, and less weight is supported as the bag narrows.

Fast Routine Maintenance

When sealing bands need to be replaced, Emplex's unique design offers quick and easy change-over. No tools are required and it takes about a minute to change. Easy access to the sealer's internal components and simple construction keep routine maintenance to a minimum.



Table-Top Band Sealer - Compact and portable, the **MPS6140** is Emplex's table-top version of the MPS6100. Ideal for lightweight sealing applications (up to 8 Oz.), the MPS 6140 sealing head tilts from 0-45° for optimum efficiency. An optional adjustable product shelf is also available.



Emplex MPS6100 Basic Band Sealer

Emplex MPS 6100 Price List

Model #	Description	Price
MPS6100	Basic Band Sealer	\$7,980
MPS6110	Band Sealer with Trimmer	\$10,185
MPS6120	Band Sealer with Embosser	\$10,290
MPS6130	Band Sealer with Printer	\$13,125
MPS6140	Table-Top Band Sealer	\$5,145
MPS6150	Band Sealer w/Printer & Trimmer	\$15,330
MPS6160	Band Sealer w/Embosser & Trimmer	\$12,495
Option	Casters	Included
Option	Product Shelf	\$263
Option	Stainless Steel Pressure Roller Assy.	N/C
Option	220V Electrical	N/C
Option	Left-to-Right Infeed	N/C
Option	Mounting Brackets for Horizontal Use	\$263
Option	Timed Off for Sealer	\$126
Option	Non-Standard Seal Width	N/C
SK-Stand	Standard Spare Parts Kit	\$368
SK-Trim	Trimmer Spare Parts Kit	\$126
Type-EM	Embosser Type (per character)	\$17
Type-PR	Printer Type (per character)	\$16
1P1250	Replacement Teflon Belt	\$18.50
FOB: Factory, Ontario, Canada.		

Technical Specifications of the MPS6100 Series

Electrical	115VAC, single phase, 60 Hz, 600W, 6 amps
Motor	Variable speed DC drive
Speed	Variable up to 480 inches per minute
Temperature Controller	PLC
Temperature Range	150-500F (65-260C)
Seal Width	1/4"
Sealing Bands	Etched Teflon
Weight	Approx. 107 lbs. (6140 approx. 65 lbs.)
Dimensions	45-57" H (adj.) x 53" W x 27" D



EMPLEX CONVEYORIZED BAND SEALERS



Emplex MPS6500 Conveyorized Band Sealer

The **Emplex MPS6500 Conveyorized Band Sealer** is the conveyorized mate to the MPS6100 Series, and is required for bag weights greater than 2 pounds or for particular product orientation. They feature stainless steel, food-grade belt conveyors complete with adjustable guide rails. The standard conveyor size is 6" wide x 6' long, with a full family of conveyor options and sizes available to meet your specific needs. MPS conveyors are effortlessly mounted directly to the floor stand. Easy to adjust with a dependable latch mechanism, MPS conveyors are manually raised and lowered to match any size bag.

Like the MPS6100, the MPS6500 boasts a wide range of standard features and capabilities. These continuous feed sealers have a standard control panel with the new PLC control system with touch screen HMI interface for programming and monitoring your sealer performance. The MPS Series utilizes variable pressure sealing bars for the sealing process which accommodate for variation in bag thickness or composition, ensuring a hermetic seal every time. All seals are created using economical etched Teflon bands which maintain high seal quality and produce consistently strong, clean seals on all heat sealable bags.

Emplex MPS6500 Price List

Model #	Description	Price
MPS6500	Conveyorized Band Sealer	\$11,125
MPS6510	Conveyorized Band Sealer with Trimmer	\$13,330
MPS6520	Conveyorized Band Sealer with Embosser	\$13,435
MPS6530	Conveyorized Band Sealer with Printer	\$16,270
MPS6550	Conv. Band Sealer with Printer & Trimmer	\$18,475
MPS6560	Conv. Band Sealer w/Embosser & Trimmer	\$15,640
Option	Casters	Included
Option	Product Shelf	\$263
Option	Stainless Steel Pressure Roller Assy.	N/C
Option	220V Electrical	N/C
Option	Left-to-Right Infeed	N/C
Option	Non-Standard Seal Widths	N/C
Option	Timed Off	\$126
SK-Stand	Standard Spare Parts Kit	\$368
SK-Trim	Trimmer Spare Parts Kit	\$126
Type-EM	Embosser Type (per character)	\$17
Type-PR	Printer Type (per character)	\$16
1P1250	Replacement Teflon Belt	\$18.50

FOB: Factory, Ontario, Canada.

Add-On Versatility

A number of add-on options modify and enhance the sealing functionality of this series. These options include: trimmers, printers, embossers, perforation units and more. This add-on principle means you can add-on any of these options at any time to the sealing unit, even after the purchase. Most take just a few bolts to add-on. See page 28 for more information on the options.

Minimized Seal to Product Distance

MPS Series machines reduce empty space found between the product and seal to its smallest physical limit, thereby reducing bag wastage, increasing shipping volume, and enhancing product appearance.

Fast Routine Maintenance

When sealing bands need to be replaced, Emplex's unique design offers quick and easy change-over. No tools are required and it takes about a minute to change. Easy access to the sealer's internal components and simple construction keep routine maintenance to a minimum.

Unique Stand Design

The newly designed stainless steel stand is as functional as it is durable. The stand is height adjustable by crank wheel.

Technical Specifications of the MPS6500 Series

Electrical	115VAC, single phase, 60 Hz, 600W, 6 amps
Motor	Variable speed DC drive
Speed	Variable up to 480 inches per minute
Temperature Controller	PLC
Temperature Range	150-500F (65-260C)
Seal Width.....	1/4"
Sealing Bands	Etched Teflon
Weight.....	Approx. 165 lbs.
Dimensions	45-57" H (adj.) x 82" W x 27" D

**For More Options
See Page 26**



EMPLEX HEAVY DUTY BAND SEALERS

Engineered for demanding environments, the **Emplex MPS7000 Series of Heavy-Duty Band Sealers** tackle heavy-duty, high-speed production requirements with ease. Built standard with 10" of heating and 10" of cooling (double the capacity of the MPS6000 series), each 5" heating section is controlled independently with the new PLC control system with touch screen HMI interface for programming and monitoring your sealer performance. Variable speeds can be reached over 750" per minute.

The MPS7000 series utilizes variable pressure sealing bars for the sealing process which accommodate for variations in bag thickness or composition, ensuring hermetic seals every time. All seals are created using economical etched Teflon bands. The infeed system is capable of supporting significant bag weights without the use of a conveyor. Typically, the MPS7000 can support a 10" wide bag containing 2 pounds of product.

Conveyorized Units

For bags that require more support, the conveyorized MPS7500 series is the ideal solution. The standard conveyor size is 6" wide x 6' long, with a full family of conveyor options and sizes available to meet your needs. All conveyors are stainless steel, food-grade belt conveyors, complete with adjustable guide rails and are easy to manually raise and lower.

Add-On Versatility

A number of add-on options modify and enhance the sealing functionality of this series. These options include: trimmers, printers, embossers, conveyors, perforation units and more. This add-on principle means you can add-on any of these options at any time to the sealing unit, even after the purchase. Most take just a few bolts to add-on. See page 26 for more info on the options.

Fast Routine Maintenance

When sealing bands need to be replaced, Emplex's unique design offers quick and easy change-over. No tools are required and it takes about a minute to change. Easy access to the sealer's internal components and simple construction keep routine maintenance to a minimum.

Technical Specifications - MPS7100 & 7500 Series

Electrical ..115VAC, 1-phase, 60 Hz, 1500-2645W, 13-23 amps
 MotorVariable speed DC drive
 Speed-Standard.....Variable up to 750 inches per minute
 Speed-OptionalVariable up to 1000 inches per minute
 Temperature ControllerPLC
 Temperature Range150-500F (65-260C)
 Seal Width1/4"
 Sealing Bands.....Etched Teflon
 Weight.....Approx. 134 lbs. (7100Series)
Approx. 182 lbs. (7500 Series)
 Dimensions45-57" H (adj.) x 64" W x 28" D (7100 Series)
45-57" H (adj.) x 82" W x 28" D (7500 Series)



Emplex MPS7500 Dual-Heat Heavy Duty Band Sealer

Emplex MPS7000 Price List

Model #	Description	Price
MPS7100	Dual-Heat Band Sealer	\$11,455
MPS7110	Dual-Heat Band Sealer with Trimmer	\$13,650
MPS7120	Dual-Heat Band Sealer with Embosser	\$13,755
MPS7130	Dual-Heat Band Sealer with Printer	\$16,590
MPS7150	Dual-Heat Band Sealer with Printer & Trimmer	\$18,795
MPS7160	Dual-Heat Band Sealer w/Embosser & Trimmer	\$15,960
MPS7500	Conveyorized Dual-Heat Band Sealer	\$14,590
MPS7510	Conveyorized Dual-Heat with Trimmer	\$16,795
MPS7520	Conveyorized Dual-Heat with Embosser	\$16,900
MPS7530	Conveyorized Dual-Heat with Printer	\$19,735
MPS7550	Conveyorized Dual-Heat w/Printer & Trimmer	\$21,940
MPS7560	Conveyorized Dual-Heat w/Embosser & Trimmer	\$19,105
Option	Casters	Included
Option	Product Shelf	\$263
Option	Stainless Steel Pressure Roller Assembly	N/C
Option	220V Electrical	N/C
Option	Left-to-Right Infeed	N/C
Option	Third Heater Section	call
SK-Stand	Standard Spare Parts Kit	\$473
SK-Stand/Trim	Trimmer Spare Parts Kit	\$126
Type-EM	Embosser Type (per character)	\$17
Type-RPR	Printer Type (per character)	\$16
1P0443	Teflon Belt	\$26
FOB: Factory, Ontario, Canada.		

**For More Options
See Page 26**



The Emplex ACS6200 / 7200 Semi-Automatic Bag Sealing System has been designed for high-speed horizontal and angled sealing applications. It is ideal for bakery products (tortillas, pita bread, pizza shells), hosiery products (socks, shirts, underwear), paper products, trays, cases, magazines, mailers, etc. This system has been designed to work with manual, semi-automatic, or fully automatic loading systems. With four conveyor lengths to choose from, multiple loading stations can be utilized to achieve the highest production rate possible.

There are three components to the ACS System: the sealing head, a main carrying conveyor and an adjustable l-belt conveyor. These three components are driven by their own motors and are synced by a master/slave system.

The 6200/7200 Band Sealer

The sealing head is a band sealer that is mounted on an adjustable L-belt style conveyor. The ACS6200 sealers are a variation on the Emplex MPS6000 style band sealer. The ACS7200 are a variation on the MPS7000 Series. Like the MPS, the ACS boasts a wide range of standard features and capabilities. These continuous feed sealers have a standard control panel with the new PLC control system with touch screen HMI interface for programming and monitoring your sealer performance. The ACS utilizes variable pressure sealing bars for the sealing process which accommodate for variation in bag thickness or composition, ensuring a hermetic seal every time. All seals are created using economical etched Teflon bands which maintain high seal quality and produce consistently strong, clean seals on all heat sealable bags. The main difference is that the ACS Series carrying belt that carries the bag through the sealer, runs on the same plane as the sealing bands. This design enables the closest product-to-seal distance available on any continuous sealer. The ACS also features a wide-mouth opening on the seal head for easier infeeding of the bag. The sealer mounting system allows for infeed height adjustment.

The ACS Conveyor

The ACS Conveyor is an adjustable L-belt style conveyor. The main conveyor unit is designed to handle bags up to 15" in length (measured from the bottom of the bag to the top of the seal). Adjusting the conveyor for different bags sizes is simple and quick--no tools are required. The standard width of the main carrying conveyor is 12" wide and lengths of 6', 9', 12', and 15' are available. Every model but the 6' can be outfitted with an air removal compression belt system. The conveyor can be angled with a 0-60° pitch.

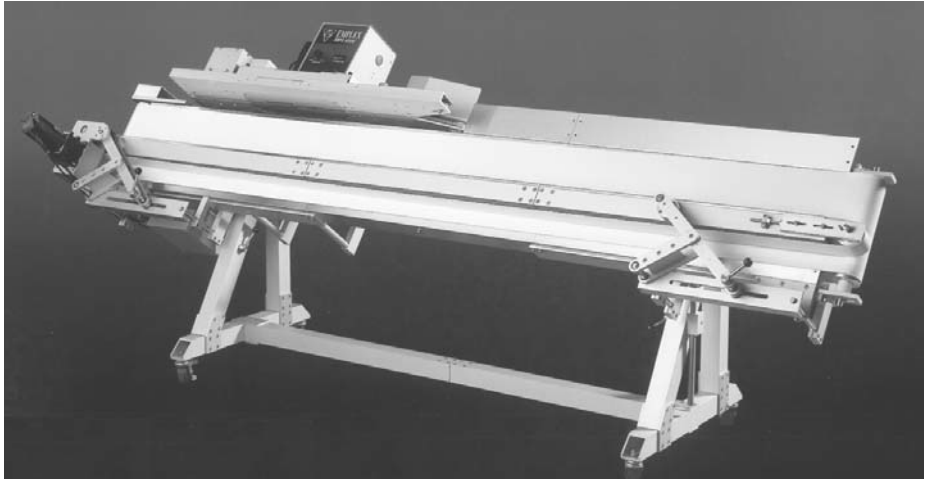

Emplex ACS6200 Semi-Automatic Bag Sealing System shown with 6230 Sealer with Printer and ACS9 Conveyor 9 ft x 12".

ACS6200/7200 Semi-Automatic Sealing System

Sealer Model	Configuration
ACS6200/7200	Standard Band Sealer
ACS6210/7210	Standard Sealer with Front-End Trimmer
ACS6220/7220	Standard Sealer with Emboss Coder
ACS6230/7230	Standard Sealer with Dry Ink Printer
ACS6250/7250	Standard Sealer with Front End Trimmer & Dry Ink Printer
ACS6260/7260	Standard Sealer with Front End Trimmer & Emboss Coder
FOB: Factory-Ontario, Canada	

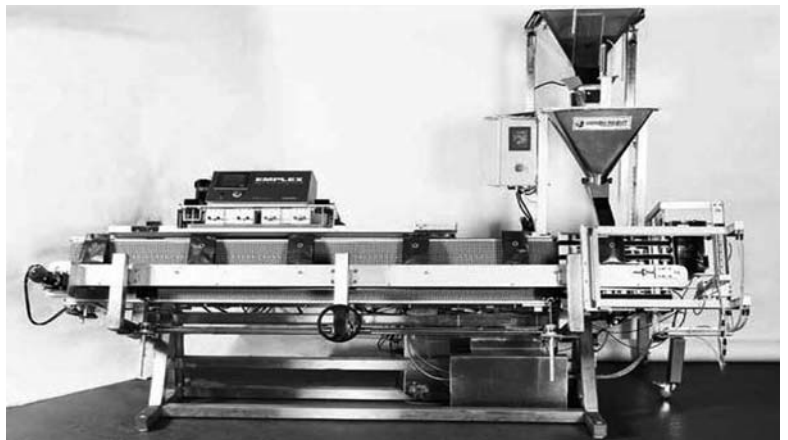

InstaPack - Fully Automated Bag Sealer

Plexpack's InstaPack Automated Bagging System opens, places and hermetically seals nearly any printed and non-printed bag material. InstaPack is the ideal solution when automatically bagging for a wide range of products, including food and medical products.

It is easily paired with fillers and scales to create an ideal bagging solution for coffee, powdered products, and fresh meat, poultry and seafood. It packages products weighing up to 10 lbs. with a finished size up to 8 inches wide and 20 inches tall.

InstaPack is modular and simple to maintain and upgrade as needed. A common optional add on is a small bag end effector for dual bag fills and range of printing options.



EMPLEX PORTABLE BAND SEALER

The **Emplex MPS Lite Portable Rotary Band Sealer** is a continuous load machine designed for portable sealing applications as well as low production sealing requirements.

At only 11 lbs., the sealer is light enough to carry and has been weighted with the user in mind to allow for either portable or stationary sealing. It comes with a table top stand.

It features a digital PID autotune temperature controller and a variable spring pressure system. You can easily set the appropriate sealing parameters for your particular bag or material.

Whether you are sealing liners in a drum, looking to seal a small number of bags per hour, or in need of a cost effective backup to your production sealer, the *MPS Lite* can do the job.

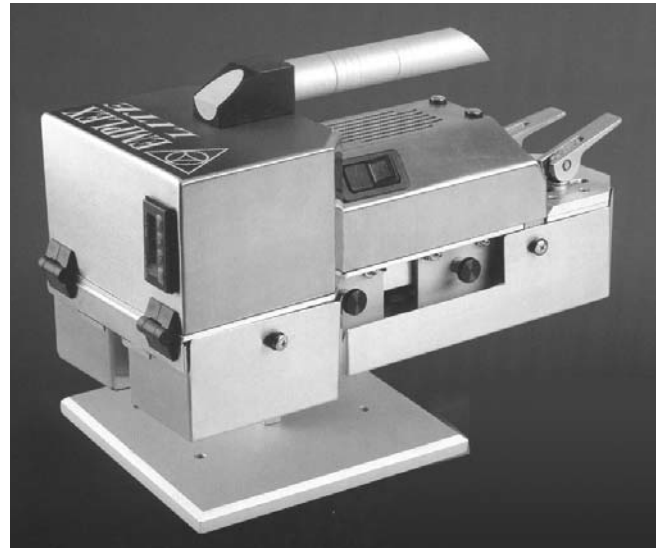

Emplex MPS Lite Portable Band Sealer

Emplex MPS Lite - Technical Specifications

Seal Width	3/8"
Dimensions	6"W x 7.5"H x 14.5"L
Approximate Weight	11 pounds
Throat Depth	1-1/4" from bottom of the seal
Approximate Speed.....	180 inches per minute, fixed rate
Uses	Designed to seal bags 5 mil thick or less
Construction	Anodized aluminum and stainless steel
Electrical	115 VAC, 60 Hz, 2 amps, single phase
Motor	Fixed speed AC drive
Table Top Stand	Included

Model #	Description	Price
MPS Lite	Rotary Band Sealer	\$3,570.00
1P1273	Replacement Teflon Band	\$18.50
SPK Lite	Spare Parts Kit for MPS Lite	\$289.00

EMPLEX BAND SEALER ACCESSORIES

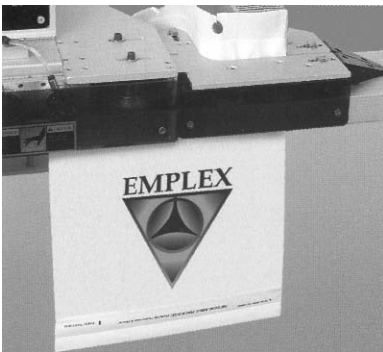

The MPS6110, MPS6150, & MPS6160 (and corresponding 6200, 6300, 6500, 6700, 7100, 7500 series models) are equipped with the **Front-End TR60 Bag Trimmer**. The blade is height adjustable for accurate trim positioning. Scrap is positively removed by our trim belt system, so there is no need for fan blowers or vacuum systems. The trimmer unit is easily and quickly removed for servicing or non-trimmed sealing.

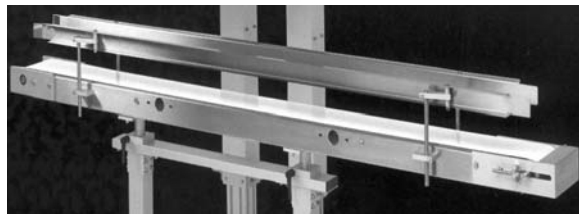

The MPS6500,6700, and 7500 Series are equipped with the Emplex **Standard MPS 6' x 6" Conveyor**. Required for bag weights greater than 2 pounds. All conveyors are stainless steel, food-grade belt conveyors complete with adjustable guide rails. MPS conveyors are effortlessly mounted directly to the double-post floor stand. Easy to adjust with dependable latch mechanism, MPS conveyors are manually raised and lowered to match any size bag. Larger heavy duty conveyors available

Emplex Band Sealer Accessories	
The MPS Series of Emplex Band Sealers is modular--so any of these accessories can be ordered with the machine or easily added later.	
Accessory	Price
TR60 Front-End Bag Trimmer	\$2,205
MPS 6' x 6" Conveyor	\$3,145
MPS 12" Heavy Duty Conveyors	call
PR60 Back-End Dry Ink Printer	\$5,145
ER60 Back-End Emboss Coder	\$2,310



The MPS6130 & MPS6150 (and corresponding models in other series) are equipped with the **Back End PR60 Dry Ink Printer**. Capable of holding up to 17 or 23 characters per line, this printer features adjustable type pressure and comes in single, double, or triple line versions.

The MPS6120 & MPS6160 (and corresponding models in other series) are equipped with the **Back End ER60 Emboss Coder**. The ER60 holds up to 8 characters of standard type and 13 characters of slim type, and is available in single line or double line versions.



FRM-1120C ECONOMY BAND SEALER



FRM-1120C Stainless Steel Band Sealer

The **FRM-1120C Economy Band Sealer** is made of stainless steel. The seal head and conveyor may be tilted up to 30 degrees to allow for the sealing of free flowing products as well as packages with some liquid content. It is equipped with a standard hot stamp embosser, a fully adjustable stand, and a conveyor. The sealing speed is 0-320 inches/minute and the seal width is 5/16". The sealing temperature range is 0-300 degrees Celsius and the maximum conveyor load is 16 lbs.

Standard Features:

- Durable stainless steel construction
- Tilting seal head, which allows the machine to tilt up to 30 degrees
- Suitable for any product including liquids
- Solid state temperature controller that maintains the seal bars at the proper temperature for consistent seal quality
- Fully adjustable conveyor (both conveyor height and depth in relation to seal bars can be adjusted)
- Dry ink coding allows for printing on the seal line - 3 lines, 20 characters/line
- Unit feeds from Right to Left
- Spare Parts Kit includes: PC board, Teflon belt, wheel belt, carbon brush, element, & type set.

Model No.	Price
FRM-1120C Band Sealer	\$2,725.00
TB-FRM-1120C Teflon Belt	\$7.50

HL-810E TABLE TOP ECONOMY BAND SEALER



The **HL-M810e Table Top Economy Band Sealer** is suitable for sealing all types of thermoplastic materials and bags. This sealer can be used in a variety of fields such as the food, electronics, and cosmetic industries. Can seal 20-30 6" poly bags in one minute. HL-810e uses dry ink coding to print numbers or letters on the seal line.

Standard Features:

- Durable stainless steel construction
- Easy to operate - minimal operator training
- Emergency stop - safety feature
- Solid state temperature controller that maintains the seal bars at the proper temperature for consistent seal quality
- Fast warm-up time
- Fully adjustable, motorized, rubber conveyor (both conveyor height and depth in relation to seal bars can be adjusted) with speed control
- Knurled pressure rollers with variable pressure adjustment
- Sealing method - constant/direct heat with 2 heating & cooling blocks
- Dry ink coding allows for printing on the seal line - 2 lines, 20 characters/line (optional 3 lines, 20 characters/line)
- Unit feeds from Left to Right
- Spare Parts Kit includes: PC board, PTFE belt, wheel belt, fuse, motor brush, heating element, silica gel ring, silicone pin & type set.

Model No.	Price
HL-810e Table Top Band Sealer	\$1,200.00
Machines usually ship in 1-2 days, FOB: Inglewood, CA. Must ship by truck freight.	





AUDION 552 HORIZONTAL BAND SEALERS

Audion Model 552 High Production Band Sealers seal most of the modern packaging materials such as PE, PP, PVC, Polycello, Laminated and Mil Spec. All models come standard with a digital temperature controller that gives accurate control to a maximum temperature of 550° F (288° C). The jaw pressure is adjustable to differing material widths. The standard seal width is 7/16" and 1/8", 5/16" and 13/16" are optional on a custom order basis.

The **Audion 552 is a Horizontal Sealer with integral conveyor**--so the conveyor belt and sealing belts stay in sync. The conveyor and sealing head can be tilted to any position up to 30 degrees, and can be raised or lowered between 28" and 36" above the floor. The conveyor can also be lowered to 1-3/4" below the sealing belts for sealing of bulky packages. The conveyor dimensions are 12" wide and 46" long.

Also available from Audion is the **Model 555 Adjustable Head Band Sealer**. On the Model 555, the head can be rotated 90 degrees and positioned anywhere between the horizontal and vertical to accommodate various types of bag sealing applications. The sealing head can be raised or lowered between 26" and 39" from the floor. An optional motorized 54" conveyor can be integrated with the Model 555 to make production fast and easy.

The Audion Band Sealers are made for working all day, and with an adjustable sealing speed of up to 400" per minute, a high rate of production can be achieved. Reliable and requiring little maintenance, the Audion Bandsealer provides a strong, hermetic airtight seal, bag after bag with no rejects. Seal integrity is excellent and the machine is easily qualified for the most demanding applications. Versatile, it can seal the lightest as well as the heaviest of flexible heat sealable packaging materials. Models come standard with a durable painted steel finish.

An adjustable cutter is a very popular option on the Audion Bandsealer, the cutter can also come with a scrap remover. A Hot Stamp Printer is also available to imprint up to 2 lines of 12 characters each in the sealing area. An embossing device to encode in the sealing area is also available.

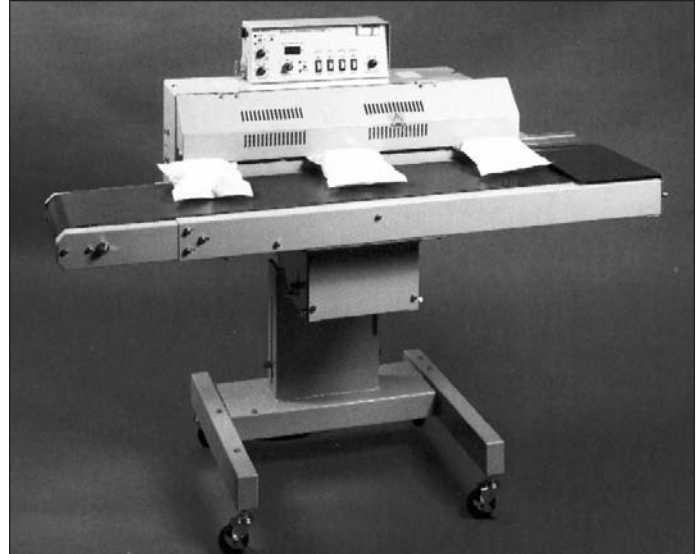

Audion Model 552 Band Sealer with integral conveyor.

Audion Band Sealers

Model #	Price
552NH Horizontal Band Sealer w/conveyor	\$11,005.00
552SS Stainless Steel Horiz. Band Sealer	\$15,080.00
555NTV Adjustable Head Band Sealer	\$9,565.00
555SS Stainless Steel Adj. Head Band Sealer	\$12,930.00
555C Conveyor for 555 Sealer	\$2,250.00
Options:	
Cutter - Installed	\$2,600.00
Cutter with Vacuum Scrap Removal	\$4,550.00
Hot Stamp Printer - Installed	\$4,480.00
Embossing Wheel - Installed	\$745.00
Characters for Embosser or Printer	\$15.00/each
8T63507TG Teflon Seal Belt (2/Pack)	\$130.00/pack
FOB: San Rafael, CA	



Audion Model 555 Adjustable Head Band Sealer shown with optional conveyor.

On Sale!



Stock Photo.

On Sale! Clamco 1075 Table Top Automatic Rollbagger.
Demo unit in like new condition.
New - \$9,370
SALE PRICE - \$6,495



West Coast Plastics Equipment Inc., 623 S. Hindry Ave., Inglewood, CA 90301 (new address)
CALL TO ORDER 800-392-8569 / 310-215-3186 or FAX 310-642-0468 01/17
Web Page: www.wcpsealers.com E-Mail: sales@westcoastplastics.com

MEDICAL HEAT SEALER VALIDATION (P. 29-33)

TIME, TEMPERATURE & PRESSURE CONTROL

Packaging plays an important role in assuring the sterility of medical devices and instruments from manufacture to point of use. Applying effective heat seals to the bag or pouch of terminally sterilized medical devices is arguably the most critical step to ensure the sterility of a product when it comes into contact with a patient. No matter how good the sterilization and disinfection process is, if the packaging and seal closures of a medical pouch are compromised, there is significant risk of product contamination during shipping and storage that could pose serious danger to the patient.

The regulatory standard for validation of the heat sealing process for medical applications is ISO 11607-2:2006. It specifies the validation requirements for the forming, sealing, and assembly process for the packaging of terminally sterilized medical devices. The objective of seal process validation is to document the sequence of events in which the process is established to produce effective seals that maintain sterility to the point of use and do so in a repeatable, reliable way. ISO 11607 characterizes heat sealing as achievable with a bar sealer (constant heat), impulse sealer, or a continuous feed sealer (rotary band sealer) and defines the critical parameters to create a proper seal as temperature, pressure, and heat and dwell time. These critical process parameters should be controlled, monitored, and documented. In the event that the critical process parameters are outside of predetermined tolerances, alarms, warning systems and/or machine stops are initiated. Additionally, the critical process instruments and sensors must be calibrated.

Temperature: A digital temperature controller or PLC monitors and controls the temperature of the sealing bars or sealing wire element based on feedback from the temperature sensor. For an additional level of security, temperature verification ports that are accessed externally can allow an operator to connect a calibrated temperature sensor and verify temperature accuracy against the sealer's temperature controller.

Pressure: Readings on the seal jaws or heating/cooling bars are more accurate if pressure is delivered through pneumatic air solenoids which can be calibrated and digitally controlled to provide consistent sealing pressure. This is in contrast to spring-based pressure which is difficult to measure accurately and not calibrated externally.

Time: In bar sealers and impulse sealers the seal time, dwell time and jaw closure time are measured and controlled by the digital temperature controller or PLC. In continuous feed (rotary band) sealers seal time and dwell time are determined by band speed which is controlled by a digital speed control or PLC.

All instrumentation, sensors, displays, and controllers are certified as calibrated and written calibration procedures are developed. Merely setting critical sealing parameters is not sufficient and all monitoring functions should show actual conditions.

PA AUDION 552MED VALIDATABLE HORIZONTAL BAND SEALER

The **Audion 552MED Validatable Band Sealer** was developed especially for the medical and related industries where the "seal integrity" of the pouches is a great concern. The 552MED gives precise control and validation of the seal temperature, jaw pressure and sealing speed. The 552 MED, has an independent digital temperature controller on each of the two jaws that control the temperature up to 550° F (285° C). If the selected temperature parameters are not met, an alarm system will prevent the entry of the next pouch into the sealer. The sealing speed, which is adjustable from 0" to 400" per minute, has a readout in inches per minute so the speed can be precisely controlled. The sealing pressure, which has a readout in p.s.i., can also be precisely controlled. For ease of bag handling, the sealing head and conveyor can be raised or lowered so that the seal position is between 28" and 36" from the floor

Standard features include:

- Independently alarmed digital temp. controllers for each heat bar
- Adjustable digital seal pressure control and alarm
- Alarmed digital speed control
- Rear mounted ports for calibration and validation
- Alarm activated gate stops process if a parameter falls out of range
- Seal width 7/16"
- Speeds from 0" to 400" per minute
- Integral conveyor (12" wide, 52" long)
- "Cool run" shut down to prevent damage to teflon belts
- Emergency stop button
- Lockable control box
- Casters



Audion 552MED Validatable Band Sealer shown with optional pouch trimmer

Item	Price
552 MED Bandsealer	\$19,585.00
Options & Replacement Parts:	
Hot Stamp Printer-installed	\$4,480.00
Embosser-installed	\$745.00
Pouch Trimmer	\$2,000.00
Pouch Trimmer w/vacuum scrap removal	\$4,550.00
FOB: San Rafael, CA	





P.A.C. MEDPAC VALIDATABLE SEALERS



P.A.C. MedPac18

The **PAC MedPac Validatable Pouch Sealer** is an air operated impulse sealer that provides validatable controls for use in the medical industry, maintaining seal integrity seal after seal. The MedVac is the vacuum sealer version of the MedPac. PAC has manufactured pouch sealers for over forty years and the MedPac and the MedVac have the same heavy duty, high production quality. Look at all the features that are standard on the MedPac!

Standard Features:

- 2 seal jaws with a 5/16" wide seal element in each jaw
- Temperature controller with digital read-out & alarm
- Independent temperature sensors measure top and bottom jaw seal elements
- Jaw selector switch that allows either jaw element to be turned on or off
- Digital timers with LED readout for seal & cool cycles
- Digital Pressure Gauge with LCD readout and programmable alarm setup
- Alarm system that will abort cycle if temperature or pressure is out of preset range
- Clear control box cover with key lock
- Ported exhaust, can be piped if needed
- Verification Plug-In Outputs useable by customer equipment for machine validation
- Stainless Steel Frame

Model	Price
MedPac18 - 18" Validatable Impulse Sealer	\$13,390.00
MedPac24 - 24" Validatable Impulse Sealer	call
MedPac30 - 30" Validatable Impulse Sealer	call
MedVac18 - 18" Validatable Vacuum Sealer	\$19,850.00
MedVac24 - 24" Validatable Vacuum Sealer	\$20,535.00
MedVac30 - 30" Validatable Vacuum Sealer	\$21,005.00
Hot Stamp Printer	\$3,055.00
Type Characters for Hot Stamp Printer	\$15.00/each
Pouch Stretcher	\$930.00
FOB: San Rafael, CA	



P.A.C. TABLE-TOP VALIDATABLE SEALERS



P.A.C. P.V.T.S. MED25B
Table-Top Validatable Vacuum Sealer

The **PAC PTS-MED** (seal only) and **PVTS-MED** (vacuum/gas seal system) are Table Top Pouch Sealers that are designed for operations needing medical seal integrity and validation with limited space, budget or lower production requirements.

Available in three sealbar lengths, the PTS-MED and PVTS-MED come with a Suretemp temperature controller; programmable pressure switch; independent vacuum, gas, seal, and cool timers (vacuum & gas on PVT-MED only); digital display; alarm system; verification ports; ported exhaust; and stainless steel construction

Standard Features:

- Digital Temperature Controller with band alarm
- Digital Seal & Cool Timers in 0.1 second increments
- Digital Vacuum Timer in 1.0 second increments (PVTS)
- Verification Ports - permit calibration and verification of seal parameters
- Pressure Switch with band alarm
- Ported Exhaust
- Stainless Steel Construction
- Hand Free Foot Switch Activation

Options:

- Biactive Seal Jaws - selector switch allows heating with top or both jaws to seal various materials (MEDB).
- Seal Only Switch (PVTS)
- Multi-Stage Capability
- Vacuum Level Sensor
- Stand and/or Workshelf

Model #	Style	Seal	Price
PTS20BMED	Seal Only	20" x 5/16"	\$8,020
PTS25BMED	Seal Only	25" x 5/16"	\$8,540
PTS30BMED	Seal Only	30" x 5/16"	\$9,055
PTS20BMEDB*	Seal Only	20" x 5/16"	\$8,785
PTS25BMEDB*	Seal Only	25" x 5/16"	\$9,305
PTS30BMEDB*	Seal Only	30" x 5/16"	\$9,820
PVTS MED20B	Vacuum/Gas	20" x 5/16"	\$11,525
PVTS MED25B	Vacuum/Gas	25" x 5/16"	\$12,080
PVTS MED30B	Vacuum/Gas	30" x 5/16"	\$12,635
PVTS MED20BB*	Vacuum/Gas	20" x 5/16"	\$12,265
PVTS MED25BB*	Vacuum/Gas	25" x 5/16"	\$12,820
PVTS MED30BB*	Vacuum/Gas	30" x 5/16"	\$13,380

* Biactive (Top & Bottom) Seal. FOB: San Rafael, CA



West Coast Plastics Equipment Inc., 623 S. Hindry Ave., Inglewood, CA 90301 (new address)

CALL TO ORDER 800-392-8569 / 310-215-3186 or FAX 310-642-0468 01/17

Web Page: www.wcpsealers.com E-Mail: sales@westcoastplastics.com

EMPLEX VALIDATABLE BAND SEALERS



Emplex MPS6300 Validatable Band Sealer

The **Emplex MPS6300 & MPS6700 Validatable Series Band Sealers** boast a wide range of standard features and capabilities. These continuous feed, variable speed machines include: one pair of air pressurized, digitally controlled heaters bars; one pair of air flow, air pressurized cooling bars; with the new PLC control system with touch screen HMI interface for programming and monitoring your sealer performance and a safety interlock switch which turns the machine off when the control panel is opened. There is also an internal switch which turns off the front heater bars, improving the sealing of Tyvek pouches. Calibration can be done at the Emplex factory or by your own testing facilities. All seals are made using economical etched Teflon bands which maintain high seal quality and produce consistently strong, clean seals on all heat sealable bags.

Validation Control

The MPS Validatable Series Band Sealers has a control system that runs the sealer with a PLC and includes 2 or 3 closed loop temperature controls, 1 closed loop speed control, 1 closed loop air pressure control. The program menu can hold up to 9 recipes for easy changeover to different bags. The alarm menu ensures that bags are sealed only within programmed parameters, when the machine will stay in reverse so that no bag can be loaded while the sealer is out of tolerance.

Add-On Versatility

A number of add-on options modify and enhance the sealing functionality of this series. These options include: trimmers, printers, embossers, conveyors, perforation units and more. This add-on principle means you can add-on any of these options at any time to the sealing unit, even after the purchase. Most take just a few bolts to add-on. See page 28 for more information on the options.

Strong Support Capability

Emplex's exclusive infeed system is capable of supporting significant bag weights without the use of a conveyor. Typically, the MPS6300 can support a 10" wide bag containing 2 pounds of product. More weight can be supported with wider bags, and less weight is supported as the bag narrows. For heavier products or ease of production, use the MPS6700 Series Conveyorized Validatable Band Sealers.

Emplex MPS6300/6700 Price List

Model #	Description	Price
MPS6300	Basic Validatable Band Sealer	\$12,915
MPS6310	Validatable Band Sealer with Trimmer	\$15,120
MPS6320	Validatable Band Sealer w/ Embosser	\$15,225
MPS6330	Validatable Band Sealer w/ Printer	\$18,060
MPS6340	Table Top Validatable Band Sealer	\$9,975
MPS6350	Valid. Sealer with Printer & Trimmer	\$20,265
MPS6360	Valid. Sealer w/Embosser & Trimmer	\$17,430
MPS6700	Conveyorized Validatable Band Sealer	\$16,060
MPS6710	Conveyorized Validatable w/Trimmer	\$18,265
MPS6720	Conveyorized Validatable w/Embosser	\$18,370
MPS6730	Conveyorized Validatable w/Printer	\$21,205
MPS6750	Conv. Valid. w/Printer & Trimmer	\$23,410
MPS6760	Conv. Valid. w/Embosser & Trimmer	\$20,575
Option	Casters	Included
Option	Product Shelf	\$263
Option	Stainless Steel Pressure Roller Assembly	N/C
Option	Non-Standard Seal Width	N/C
Option	Timed Off	\$126
Option	220 Volt Electrical	N/C
Option	Left-to-Right Infeed	N/C
SK-Stand	Standard Spare Parts Kit	\$368
SK-Stand/Trim	Trimmer Parts Kit	\$126
Type-EM	Embosser Type (per character)	\$17
Type-PR	Printer Type (per character)	\$16
1P1250	Teflon Band (etched)	\$18.50

FOB: Factory, Ontario, Canada.

More Options Page 26



Emplex MPS6340

Compact and portable, the **MPS6340** is the table-top version of the MPS6300. Ideal for lightweight sealing applications (up to 8 oz.), an optional adjustable product shelf is offered for consistent loading and sealing performance.





ACCU-SEAL VALIDATABLE SEALERS

Series 5300 Medical Sealers

Built to detailed and documented specifications the new **Accu-Seal Series 5300 Heat Sealers** deliver equivalence throughout your facility, with repeatable, reliable performance. 100% validatable and calibratable across all seal parameters, ISO 11607, CE compliant. Fully lock out protected alarmed digital process control, and high speed PLC and LCD touch screen HMI provide the confidence all process parameters are maintained Seal-to-Seal. Accu-Seal Heat sealers are designed to meet clean room packaging requirements for sealing a variety of pre-made pouch materials. External verification ports offer ease of calibration.

This robust machine has many standard features to enhance production. Intuitive, User-friendly operation with password protection and Alarms ensures total process control. The Seamless Stainless Steel enclosures, product support tray, and 3/8" seal width are all standard features on this machine, built to perform for years.



Accu-Seal Model 5300 Series Medical Heat Sealer

Model	Seal Width	Seal Length	Size L x W x H	Price
5300-15-B	3/8"	15"	21 x 10 x 8	\$5,537.00
5300-20-B	3/8"	20"	26 x 10 x 8	\$5,787.00
5300-25-B	3/8"	25"	31 x 10 x 8	\$6,037.00
Options				
816-000# Machine Stand (15", 20", & 25") (see p. 16)				\$940.00
Initial Calibration				\$415.00
220 Volt Electrical				\$275.00
108-0010 Ultra Quiet Lab Compressor				\$2,095.00
FOB: San Marcos, California.				

Built-In Features:

- LCD touch screen and PLC digital control
- Pressure regulator with Gauge
- Password protected control
- External calibration verification output ports
- Visible and audible alarms
- Emergency stop
- Safe, Low-force jaw close
- Lower heat 3/8" seal width
- Seal count
- Stainless steel product support tray
- Seamless stainless steel case
- Clean room friendly, external exhaust port

Series 6300 Medical Sealers

Built to detailed and documented specifications the new **Accu-Seal Series 6300 Heat Sealers** deliver equivalence throughout your facility, with repeatable, reliable performance. 100% validatable and calibratable across all seal parameters, ISO 11607, CE compliant. Fully lock out protected alarmed digital process control, and high speed PLC with LCD touch screen HMI provide the confidence all process parameters are maintained Seal-to-Seal. Accu-Seal Heat sealers are designed to meet clean room packaging requirements for sealing a variety of pre-made pouch materials. External verification ports offer ease of calibration.

This robust machine has many standard features to enhance production. Intuitive, User-friendly operation with password protection allows the operator to select from pre-set & named seal recipes to maximize changeover speed without compromising process control. Alarms for process faults, seal count, alarm history, and product support tray are all standard features on this robust machine, built to perform for years.



Accu-Seal Model 6300 Series Medical Heat Sealer

Series 6300 Medical Sealers

Model No.	Seal Length	Seal Width	Size L x W x H	Price
6300-15-B	15"	3/8"	21 x 12 x 8	\$7,420.00
6300-20-B	20"	3/8"	26 x 12 x 8	\$7,720.00
6300-25-B	25"	3/8"	31 x 12 x 8	\$8,120.00
6300-30-B	30"	3/8"	36 x 12 x 8	\$8,520.00
220 Volt Electrical				\$200.00
FOB: San Marcos, CA.				

Built-In Features:

- LCD touch screen and PLC digital control
- Password protected control
- External calibration verification output ports and entry of offset values via touch screen
- Visible and audible alarms
- Emergency stop
- Safe, Low-force jaw close
- Programmable seal recipes with name feature
- High force seal jaw
- Upper heat 3/8" seal width
- Seal count
- Product support tray
- Seamless stainless steel case
- Clean room friendly, external exhaust port



West Coast Plastics Equipment Inc., 623 S. Hindry Ave., Inglewood, CA 90301 (new address)

CALL TO ORDER 800-392-8569 / 310-215-3186 or FAX 310-642-0468 01/17

Web Page: www.wcpsealers.com E-Mail: sales@westcoastplastics.com



ACCU-SEAL MEDICAL SEALERS

Series 6400 Constant Heat Medical Sealers

Accu-seal 6400 Series Constant Heat Medical Pouch Sealers assure the highest level of process control. Superior process protection, innovative technology ensure repeatability and reliability where speed and accuracy are critical.

Built to detailed and documented specifications Accu-seal 6400 Series Constant Heat Sealers deliver equivalence throughout your facility, with repeatable, reliable performance. 100% validatable and calibratable across all seal parameters, ISO 11607, CE compliant. Fully lock out protected alarmed digital process control with +/- 1 degree accuracy. The high speed PLC with LCD touch screen HMI provides the confidence all process parameters are maintained Seal-to-Seal. External verification ports offer ease of calibration.

This robust machine has many standard features to enhance production. User-friendly password protection allows the operator to select from pre-set & named seal recipes to maximize production changeover speed without compromising process control. Seal count, auto cycle feature, and alarms for process faults are all standard features on this robust machine, built to perform for years.

The seamless, stainless steel cases are laser cut and welded so there are no screws to come loose, and bulkhead fittings where any cable or hose enters or exits the case, designed for easy periodic maintenance and to last for decades. Two Year Limited Warranty.



Accu-Seal Model 6400 Series Medical Heat Sealer

Built-In Features:

- LCD touch screen and PLC digital control
- Password protected control of all settings
- External calibration verification output ports and entry of offset values via touch screen
- Visible and audible alarms
- Emergency stop
- Alarmed seal bar safety guard
- Safe, Low-force jaw close
- Safety heater off/no air supply
- Programmable seal recipes with name feature
- High force seal jaw
- Auto cycle mode
- Upper heat platen
- Seal count
- Product support tray
- Seamless stainless steel case
- Clean room friendly, external exhaust port

Series 6400 Medical Sealers

Model No.	Seal Length	Seal Width	Shipping Weight	Price
6400-08-B	8"	3/8"	15	\$8,165.00
6400-15-B	15"	3/8"	35	\$8,520.00
6400-20-B	20"	3/8"	40	\$9,020.00

Options

220V Conversion	\$200.00
Initial Calibration	\$415.00

FOB: San Marcos, CA.



Accu-Seal Model 8000 Series Medical Vacuum Sealer

“New” Series 8000 Medical Vacuum Sealer

The New Accu-Seal 8000 Series Medical Vacuum Sealer is the first with the innovative “Quick-Release” vacuum system. The New “Quick-Release Vacuum System” is an innovative design allowing the user to easily remove the vacuum system and seal bar for simplified cleaning, sterilization and maintenance. The new vacuum and seal bar design accommodates a pouch with as little as 1” header space.

The new linear element tensioner has no exposed electrical connections, won’t allow binding, assures element tension under all pressure settings. The new design simplifies element replacement and extends element life.

Features include smaller footprint, modular design, simplified operator interface, alarms for process faults, multiple operating modes, multiple recipe storage, and upper/lower heat. This robust machine delivers all these features built to perform for years. Two Year Limited Warranty.

100% validatable and calibratable, ISO 11607, CE and RoHS compliant. Fully lock out protected alarmed digital process control, through LCD touch screen HMI, provides the confidence all process parameters are maintained Seal-to-Seal. External verification ports offer ease of calibration.

Built-In Features:

- Full digital, High-speed, PLC controller with color enhanced LCD touch screen HMI
- NEMA 4X stainless steel enclosure
- Gas purge standard
- Upper & Lower heating elements
- External verification ports for calibration
- Emergency stop & safe low pressure jaw close
- Non-Particle generating venturi vacuum system
- Cleanroom clean design to Class 100

“New” Series 8000 Medical Sealers

Model No.	Seal Length	Seal Width	Shipping Weight	Price
8508-B	8"	3/8"	15	\$14,500.00
8511-B	11"	3/8"	35	\$14,800.00
8516-B	16"	3/8"	40	\$15,300.00

FOB: San Marcos, CA.

West Coast Plastics Equipment Inc., 623 S. Hindry Ave., Inglewood, CA 90301 (new address)

CALL TO ORDER 800-392-8569 / 310-215-3186 or FAX 310-642-0468 01/17

Web Page: www.wcpsealers.com E-Mail: sales@westcoastplastics.com



The **Clamco Model R1275 Rollbag** uses the latest technological innovations to give the highest throughput speed for a tabletop bagging system. The dry cycle speed is up to 60 bags/minute with a feed rate of up to 30 inches/second. The R1275 features a color touch screen interface that makes it very user friendly and easy to learn.

The **Clamco R1075 Rollbag** by the Packaging Aids Group is a fully-automatic bag filling and sealing machine designed for fast, efficient operation. It features simple operator control, automatic motorized bag advance, automatic opening, sealing and bag separation; foot pedal activated sealing or automatic cycling. Utilizing the very latest PLC technology, the R1075 is a very reliable and easy to use automatic bagging system. The PLC control screen allows operators to quickly set-up or recall packaging jobs, and also displays diagnostic help tools.

The Clamco R1075 is easy to install and supports a wide range of size and mil thickness pre-made bags-on-a-roll. This table-top bagger can process poly, food grade and anti-static bags-on-a-roll at speeds up to 30 per minute.

The R1075 and R1275 Rollbaggers offer a variety of options such as a sorting table, product feed funnels, articulating bag support tray, foam pad air expeller, and in-line printer for printing barcodes, graphics and variable text directly onto the bag.

Features & Specifications:

- Electrical Requirements: 115VAC @ 5 amps
- Compressed Air Requirements: 2-5 CFM @80 psi
- Min./Max. Bag Width: 2" to 10"
- Min./Max. Bag Length: 3" to 20"
- Shipping Weight: 81 lbs./36.5 kg
- Small Footprint: 24"W x 34"D including film roll
- Adjustable bag length control
- Fast, easy bag loading
- Adjustable air flow for bag opening
- Adjustable sealing dwell control
- Digital temperature control
- Electric footswitch or fully automatic cycle start
- Pneumatic safety release system for the seal bar



Clamco R1275 High Speed Automatic Rollbag Machine with Touch Screen Interface



Clamco R1075 Automatic Rollbag Machine shown on the optional console stand.



Optional Sorting Table with Adjustable Funnel Assembly and Foam Pad Air Expeller for Clamco R1275 and R1075.

Item	Price
Clamco R1075 Rollbag	\$9,370
Clamco R1275 Rollbag - High Speed with Touch Screen	\$11,250
Clamco R1275P Rollbag with Thermal Transfer Printer	\$19,495
Sorting Table with Adjustable Funnel Assembly	\$912
Funnel-Universal	\$397
Articulating Bag Support	\$633
Bag Spreader-Seal Flattener Fingers	\$912
Console stand	\$458
Foam Pad Air Expeller	\$283
Hot Stamp Printer	\$3,440
Photo Eye-Product Detect	\$633



CLAMCO ROLLBAG R2300



Clamco Rollbag R2300

Features & Benefits:

- Utilizes Rollbags for fast bag size changes, high speed operation and easy set-up.
- Built-in interface port integrates counters, scales, robotics and other automatic in-feed devices for fully automatic packaging.
- Self-diagnostics ensure quick problem solving.
- Low pressure closing with obstruction detection system for improving operator safety.
- Wide color touch screen is operator friendly and has clear readable prompts and alarms.
- Adjustable from Vertical to Slanted configuration.
- Designed to minimize preventative maintenance costs.
- Easy adjustable stand with casters.
- Quick roll change feature to facilitate easy and fast changeover.
- On board memory stores multiple job data.
- Batch/job counter for better accuracy.
- Designed to meet CE requirements.

Options & Accessories:

- Articulating load shelf.
- Bag Deflator.
- Seal Flattener to minimize wrinkles.
- In-line thermal transfer printer.
- Dual palm buttons with anti-tie down.
- Exit conveyors for product take-away.
- Trim Seal or Wide Seal.
- In-feed conveyors.
- Standard, adjustable, accumulating or guaranteed open funnels.
- Sealing system for film up to 15" wide.
- Bag open sensor.
- 230V, 50/60 Hz operation.
- Spare parts kit.

The **Rollbag R2300** system delivers exceptional value, speed, and flexibility for bagging operations and utilizes Rollbags (pre-opened bags-on-a-roll). Utilizing the latest technological innovations, the R2300 can fill and seal bags at rates significantly faster than manual packaging.

The Rollbag R2300 is the ultimate in reliability and ease of operation. It's quick to set-up, easy to operate, fast and reliable for hand loading, semi-automatic or fully automatic bag packaging.

With Rollbag systems, size changes and setup are a breeze using the built-in job storage feature and the large color touch-screen. Help screens and built-in diagnostics insure optimum performance and uptime.

Built-in interface simplifies integration of counters, scales, robotics and other automatic in-feed devices for in-line filling. With the printer option, the Rollbag R2300 can print graphics, bar codes, and text in-line, as each bag is indexed through the machine, eliminating the material cost and labor expense of applying labels.

The Rollbag R2300 is simply the ultimate system for fast, efficient automatic bagging.

Specifications:

- Bag Width: 2" - 12" (51mm - 300mm)
- Bag Length: 3" - 38" (76mm - 965mm)*
- Bag Thickness: 1 - 4 mil
- Feed Rate: 10 - 40 in/sec (250mm - 1000mm/sec)
- Dimensions: 55"L x 37"W x 37" - 45"H
(1130mm x 940mm x 940mm - 1150mm)**
- Electrical: 115V @ 11 amp, 50/60 Hz
- Air: 80 psi @ 5 CFM (5.5 bar @ 140 l/m)
- Controller: Programmable Logic Control
- HMI: Wide color touch screen
- Seal Length: 12"
- Seal Width: 1/8"
- Seal Bar Pass Through: 4" standard
- Speed: Dry cycle speed is over 100 bags/min.
- Shipping Weight: 420 lbs. (190 kg)
- * Longer length available
- ** Adjustable height

FLOOR STANDING AUTOMATIC MODELS

Model Number	Description	Price
Rollbag R2300	Automatic Rollbag System	\$19,615.00
Rollbag R2300P	Automatic Rollbag with Printer	\$28,160.00

FOB: Cleveland, Ohio.



In-line thermal transfer printer



Filling Funnel

Rollbags:

Rollbags are pre-opened perforated bags-on-a-roll that make packaging significantly faster than bagging with loose cut bags. They can be pre-printed up to 8 colors for high visibility retail display and brand identification. Call us for a quote.



CLAMCO

575B SEMI-AUTOMATIC ROLLBAG



The **Clamco 575B Rollbag Machine** from the Packaging Aids Group is for semi-automatic polybagging using pre-opened bags-on-a-roll. The 575B improves productivity with features such as automatic bag positioning for easy filling, and a foot-switch operated sealing system.

The Clamco 575B Rollbag automatically advances bags when the electric footswitch is activated. An internal blower system opens the bag for easy loading. The sealing system is motor powered with magnetic hold-down providing safe, positive jaw pressure. The heavy duty motor consistently dispenses bags to the filling point. The operator separates the filled bag from the roll at its perforations and places the bag in the seal area and seals it by activating the footswitch. The seal temperature is adjustable. The Clamco 575 also features a resettable production counter. Works with bags-on-a-roll from 2" x 2" up to 12" x 12". No compressed air needed, just standard 110V house current.

Model No.	Price
575B Rollbag Machine	\$2,975.00
Options	
Accumulating Work Area & Adjustable Funnel Assembly	\$299.00
Cycle Counter	\$183.00
Multi-Roll Option	\$31.00
220 Volt Electrical	\$704.00
FOB: Cleveland, Ohio.	



INGALLS CONVEYOR SYSTEMS



Ingalls Live Roller Conveyor

Ingalls Conveyors offers a wide variety of new and reconditioned conveyors and conveyor systems to integrate into your packaging line. Many types are available including:

Gravity Roller Conveyors - Using gravity as a power source, gravity roller conveyors are an excellent Solutions choice in many warehouse and fabrication facilities. From carton flow to loading or unloading trucks. There is almost always an application for gravity roller conveyor.

Live roller conveyors offer the automated facility the flexibility to merge product lines, accumulate product, and transport at high speeds. From line shaft to belt driven to V-belt drive; most modern facilities rely heavily upon power roller conveyors.

Belt conveyors are the most economical way to transport your product Solutions using light duty to heavy duty slider bed and roller bed belt conveyors. Belt conveyors can be used to elevate or lower your product as required. Fitted with trough side guards, they also are an excellent choice for bulk handling applications.

Live Roller / Accumulation conveyors include: Straight Sections, Curved Sections, 30° Spur, and 90° Spur Curves.

Call for a free consultation and quote.



West Coast Plastics Equipment Inc., 623 S. Hindry Ave., Inglewood, CA 90301 (new address)
 CALL TO ORDER 800-392-8569 / 310-215-3186 or FAX 310-642-0468 01/17
 Web Page: www.wcpsealers.com E-Mail: sales@westcoastplastics.com

iQ-1E WEIGHER SCALE



Weigh Right iQ-1E Scale table-top model

The Weigh Right iQ-1E is an entry level scale that can weigh 1 oz. to 5 lbs. of free flowing products like whole bean and ground coffee, small nuts, rice, grains, spices, small candies, teas, popcorn and similar products.

The iQ-1E is the economy model that is dependable and has many benefits.

- No change parts needed when filling from 1 ounce to 5 pounds.
- Air compressor comes standard allowing for single button start-up.
- The load cell (the most important instrument on the scale) is sensitive yet durable. It is encased to protect against dust and water damage and has 800% overload protection.
- All contact parts are stainless steel.
- Weigh bucket disconnects easily for cleaning.
- Accuracy is from 0 to .01 pounds over.
- All controls are made from off-the-shelf parts for easy maintenance and local service worldwide.
- Touch screen, menu driven controls for easy set-up and multiple features including job memory storage, batch counting, auto-zero and the self-teaching feature.

Weights & Rates* iQ-1E

1 oz. to 4 oz.	20 cpm
8 oz. to 1 lb.	15 cpm
2 lbs. to 3 lbs.	10 cpm
3 lbs. to 5 lbs.	6 cpm

* Rates are estimated. Final results determined by product density and flow characteristics. We invite you to send samples for free testing and results.

PMB-3600 LARGE VOLUME WEIGHERS

The Weigh Right PMB-3600 Series will weigh and fill 5 to 100 lbs. of many products including IQF foods, rice, nuts, candies, plastic pieces and dry foods into bags, boxes or pails. The product container can be hand placed by an operator or the PMB-3600 can be designed to fit over and interfaced with an automatic bagger or indexing conveyor. For food applications there is an optional USDA model available. The PMB-3600 uses non-proprietary touch pad controls to enter desired weight and feed rate.

The PMB-3600 Machine Features:

- One lane (PMB-3601) or two lane (PMB-3602) scale design.
- Sanitary 304SS stainless steel contact surfaces.
- 2 cubic foot supply hopper (PMB-3601)
- 4 cubic foot supply hopper (PMB-3602)
- Programmable bulk and dribble feed settings.
- Single or three tray vibratory feed system.
- Discharge spout to suit container
- Strain gauge load cell scale system sensitive to 0.02 lbs.
- Clam type weigh bucket with 3600 cubic inch weighing capacity
- Air operated discharge mechanism
- Convenient microprocessor based control panel with digital weight display (PMB-3601)
- Menu driven controls with easy-to-read graphics and help menus (PMB-3602)
- Painted steel support frame with adjustable leveling pads (stainless steel optional).
- Nema 4 control enclosure
- Cycle control by footswitch or interface cable.
- Air filter/lubricator/regulator assembly with automatic drain



Weigh Right PMB-3601 Scale

Weights & Rates*

PMB-3601		PMB-3602	
5 lbs.	12 cpm	5 lbs	24 cpm
10 lbs.	10 cpm	10 lbs	20 cpm
25 lbs.	4 cpm	25 lbs	8 cpm
50 lbs.	2 cpm	50lbs	4 cpm
100 lbs.	1 cpm	100 lbs	2 cpm
	(2 dumps)		(2 dumps)

SHRINK FILM & HEAT GUN



PolyOlefin Centerfold Shrink Film

Roll Width	1-10 Rolls	10+ Rolls
6"	\$43.50	call
8"	\$58.00	call
10"	\$72.50	call
12"	\$87.00	call
14"	\$101.50	call
16"	\$116.00	call
18"	\$130.50	call
20"	\$145.00	call
22"	\$159.50	call
24"	\$174.00	call
26"	\$188.50	call
30"	\$217.50	call
32"	\$232.00	call
34"	\$246.50	call
36"	\$261.00	call

Available Gages & Roll Sizes:

60 gauge = 4370 foot rolls

75 gauge = 3500 foot rolls

100 gauge = 2624 foot rolls

Special sizes available - call for pricing.



For applying heat to shrink film on a light production basis use the **Milwaukee Heat Gun**. Light weight and easy to use, it is very versatile for many different shaped products. Comes with a dual heat selection-- 750°F and 1000°F, produces 4100 BTUs of heat for quick shrinking of the film. Plugs into standard 120VAC plug, uses 1200 watts.

Heat Gun - \$40.00

ECONOMY I-BAR SHRINK PACKAGING SYSTEM

Economy W-350I I-Bar Sealer for Shrink Wrap Packaging



The new **W-Series Economy I-Bar Sealers** are available in 14", 20", 26", 30" and 35" seal lengths with a round heating element for cut and seal. The sealer is equipped with a film roller cradle to hold the roll of film, a film separator to divide the two layers of centerfold shrink film, a heat gun holder and a power outlet. The entire unit is steel constructed for quality and durability.

The unit also features an adjustable seal timer which can be changed according to the thickness of the shrink film.

Shrink Wrapping Systems

The SWK Shrink Wrapping Systems are perfect for getting you started. The system includes a W-Series I-Bar sealer, an HG-I Heat Gun and a 500-foot roll of shrink film. All for a very economical price.

Economy I-Bar Sealers

Part Number	Description	Price
W-350I	Economy I-Bar Sealer w/ film roller - 14"	\$255.00
W-500I	Economy I-Bar Sealer with film roller - 20"	\$270.00
W-650I	Economy I-Bar Sealer with film roller - 26"	\$337.00
W-750I	Economy I-Bar Sealer with film roller - 30"	\$420.00
W-900I	Economy I-Bar Sealer with film roller - 36"	\$487.00

Shrink Wrapping Systems

SWK-14-S3	System includes W-350I I-Bar Sealer, HG-1 Heat Gun, 12" x 500 Shrink Film	\$296.00
SWK-20-S3	System includes W-500I I-Bar Sealer, HG-1 Heat Gun, 18" x 500 Shrink Film	\$319.00
SWK-26-S3	System includes W-650I I-Bar Sealer, HG-1 Heat Gun, 24" x 500 Shrink Film	\$392.00
SWK-30-S3	System includes W-750I I-Bar Sealer, HG-1 Heat Gun, 28" x 500 Shrink Film	\$476.00



West Coast Plastics Equipment Inc., 623 S. Hindry Ave., Inglewood, CA 90301 (new address)

CALL TO ORDER 800-392-8569 / 310-215-3186 or FAX 310-642-0468 01/17

Web Page: www.wcpsealers.com E-Mail: sales@westcoastplastics.com

SEMI-AUTOMATIC L-BAR SEALERS



Damark Model SMC1620 L Bar Sealer with optional power film unwind system and air table loading station.

The **Damark Semi-Automatic L Bar Sealers** come in many different sizes and configurations to meet your shrink packaging needs. They are heavy duty, with welded steel tubular construction that is rugged and reliable, built to last. The micro-processor controlled impulse sealing system provides consistently strong seals and superior operator safety.

The Damark Series SMC Semi-Automatic L Bar Sealers come standard with magnetic lock-down and power takeaway conveyor. Options available include: casters, hot knife seal head, power film unwind and a spare parts kit.

FEATURES:

- Counterbalanced sealing head with automatic air cushion return
- Easily adjusted film cradle
- Film clamps
- Seal area raise & lower mechanism
- Micro-processor controlled impulse sealing system
- Conveniently located control panel
- Heavy duty welded steel tubular construction
- Perforation roller for air evacuation
- Built-in storage shelf
- Casters
- 220VAC, 1-phase electrical

Model No.	Seal Area W X L	Magnetic Lockdown	Takeaway Conveyor	Max. Film Width	Price
SMC1620	16 x 20	X	X	20"	\$7,140
SMC2228	22 x 28	X	X	26"	\$11,940

Custom sizes available - call for more information.
All units FOB: Ontario, Canada.

OPTIONS:

Hot Knife Sealing Headcall
 Power Film Unwind Systemcall
 Spare Parts Kit\$395



SHRINK PACKAGING HEAT TUNNELS

The **Damark Series ST & SZ Heat Shrink Tunnels** are console units with heavy gauge steel body and welded tubular steel frame, base and casters. Features include: time proportional temperature controller, twin blowers, adjustable level infeed height, energy-watch insulation, automatic shut-down cycle, adjustable speed conveyor system, easily accessed electrical controls and casters.

Model No.	Tunnel Dimensions	Tunnel Conveyor	Heating Capacity	Price
STB-16	16"W x 24"L x 9"H	Silicone Belt	3200W	\$5,285
STR-16	16"W x 24"L x 9"H	Steel Roller	3200W	\$6,040
SZX-24B-12EX	24"W x 42"L x 12"H	Teflon Mesh Belt	9600W	\$12,664
SZR-24R-12EX	24"W x 42"L x 12"H	Steel Roller	9600W	\$12,425
SZB-34B-16EX	34"W x 42"L x 12"H	Teflon Mesh Belt	14400W	\$22,220

OPTIONS:

Adjustable Height Standcall
 1.0" Closed Spaced Rollers - varies by machinecall
 Increased Chamber Height - varies by machinecall
 Discharge Conveyorcall
 Spare Parts Kit\$475
 Wrapper/Tunnel Interconnectcall
 FOB: Factory, Ontario, Canada



All-In-One Shrink Wrap System



Damark MP-3 Maxi-Pak Shrink Packaging System.



Damark MP-1 Maxi-Pak Table Top Shrink Packaging System.

The **Damark Maxi-Pak Shrink Packaging Systems** are ruggedly built and economically priced L-Sealer and Shrink Tunnel combo systems. Each system features quality, brand name components and craftsmanship, resulting in shrink packaging systems designed and built to provide years of reliable service.

Maxi-Pak MP Series L-Sealers offer a large 14" x 18" seal area with low voltage impulse sealing system and solid state temperature control. An easy-load adjustable film cradle and an adjustable product loading table are standard on the MP Series L-Sealers.

The Maxi-Pak MP Series Shrink Tunnels have a dual blower motor/heater system with 3200 watt heating capacity. The heat is controlled by a digital temperature controller. The product is moved through the tunnel by a variable speed teflon mesh belt conveyor. The tunnel chamber is 24" long, 16" wide and 9" high. This high tunnel opening gives extra flexibility in product packaging.

The Maxi-Pak is a complete shrink system and is available in three levels of automation:

MP-1: An economic table-top version, the MP-1 consists of a welded schedule 16 sheet steel construction. Standard features on this model include: manual seal bar hold down, variable speed teflon mesh belt tunnel conveyor, thermostatically controlled tunnel heat and top & side heat vents.

MP-2: The MP-2 includes a standard heavy-gauge welded steel body and legs with casters. Standard features unique to the MP-2 include: electromagnetic seal jaw hold down, variable speed teflon mesh belt tunnel conveyor, film perforator roller for vent holes, electronic temperature control on shrink tunnel, and top, side & bottom heat vents.

MP-3: This system adds a variable speed L-Sealer package takeaway conveyor to the MP-2s standard features.

Standard Features on all Maxi-Pak Systems:

- 14" x 18" sealing area
- Tubular welded steel one-piece jaw
- 24"L x 16"W x 9"H shrink tunnel
- Dual blower motor/heater system
- 3200 Watt heating capacity shrink tunnel
- Easy load film cradle
- Electronic time proportional low voltage impulse sealing system
- Adjustable product loading table

Damark Maxi-Pak Shrink Packaging Systems		
Model		Price
MP-1	Table Top System	\$7,405
MP-1HK	Table Top System w/Hot Knife	\$8,805
MP-2	Stand-Alone System	\$7,897
MP-2HK	Stand-Alone System w/Hot Knife & Film Clamps	\$9,994
MP-3	Stand-Alone System w/Takeaway Conveyor	\$9,357
MP-3HK	Stand-Alone System with Takeaway Conveyor, Hot Knife & Film Clamps	\$11,047
FOB: Factory, Ontario, Canada		

Need Shrink Film?

See Page 38



CLAMCO

COMBO JR. SHRINK SYSTEM

*The Clamco Combo Jr. A & B Shrink System*

The **Clamco Combo Junior** is a combination of a tabletop L-sealer and a tabletop tunnel. These units can be used separately or together to pack/shrink small quantities of products. The Combo Junior tabletop shrink wrap system provides many of the same high quality features of our larger combination shrink systems in a compact, tabletop design. These small machines are easy to operate and have an excellent shrink result. No tools are needed for a fast and easy setup.

The Simpulse Heat System on the L-Sealer is an impulse trim sealer allowing for lower energy use and greater safety than constant heat units. The shrink tunnel provides complete heating all around the package along with the same cool down safety controls as larger tunnels.

Features and Benefits:

- Circular Heat Chamber provides efficient and customizable air-flow for perfect packages
- Microperforation wheel makes fine holes in the film allowing trapped air to escape in the shrink process, ensuring a high quality package appearance
- Automatic cool down circuit protects tunnel controls during shutdown
- Variable speed heat tunnel for better shrink performance
- Ergonomic design with cushioned seal bar handle
- Magnetic hold down seal bar for higher strength seals (B & D models)
- 120V 60Hz operation, Optional 220V 4kW 820MB Shrink Tunnel (Model A and B only)
- 2 Year Limited Warranty

*The Clamco Combo Jr. C & D Shrink System*

Model	Combo Jr. A	Combo Jr. B	Combo Jr. C	Combo Jr. D
Seal length (end)	16"	16"	16"	16"
Seal length (side)	14"	14"	14"	14"
Film width (max)	20"	20"	20"	20"
Tunnel opening width	16"	16"	13"	13"
Tunnel opening height	8"	8"	6"	6"
Tunnel inside length	20"	20"	15"	15"
Tunnel power (watt)	2,100	2,100	1,500	1,500
Magnetic seal bar hold down	No	Yes	No	Yes
Voltage (standard)	120V	120V	120V	120V
Price	\$3,645	\$3,820	\$2,775	\$2,960

CLAMCO

1614 TABLETOP L-BAR SEALER



The **Clamco 1614 L-Bar Sealer** is a tabletop industrial sealer suitable for sealing small production quantities of packages using centerfold shrink film. The 1614 has ergonomic grip handles and a unique spring system to ease operator fatigue and increase production efficiency. It works well with all shrink films. 2 year limited warranty.

Model	1614A	1614B	1614C	1614D
Seal length (end)	16"	16"	16"	16"
Seal length (side)	14"	14"	14"	14"
Film width (max)	20"	20"	20"	20"
Max. Package Height	5.5"	5.5"	5.5"	5.5"
Film Perforator	Yes	Yes	Yes	Yes
Magnetic hold down	No	Yes	No	Yes
Electrical Requirement	115V/10A	115V/10A	220V/10A	220V/10A
Price	\$1,360	\$1,550	\$1,630	\$1,820

West Coast Plastics Equipment Inc., 623 S. Hindry Ave., Inglewood, CA 90301 (new address)

CALL TO ORDER 800-392-8569 / 310-215-3186 or FAX 310-642-0468 01/17

Web Page: www.wcpsealers.com E-Mail: sales@westcoastplastics.com



CLAMCO

TABLE-TOP SHRINK TUNNELS



Clamco 820 Table-Top Heat Tunnel for Shrink Wrap Packaging

Clamco's Model 820 Shrink Tunnel is the choice for tough, dependable long-life performance in continuous production environments. Constructed of heavy-gauge structural steel, Model 820 features a variable-speed Teflon mesh belt conveyor, air flow heat transfer, and automatic cool down timer. The Model 820 production shrink tunnel combines advanced design precision with tough, time-proven features – expertly crafted by Clamco, the industry's respected name for steadfast reliability and value.

The Clamco's Model 820 Shrink Tunnel is made in the USA and includes a 2 year limited warranty.

Features & Options:

- 16"W x 8"H x 20"L Tunnel opening
- Variable speed up to 60 fpm
- 2,100 watts heating power for complete shrinking
- 110V, 50/60 Hz for smaller operations (820MB)
- 220V, 4000 Watt for extreme operations (820HD)
- Variable speed Teflon mesh belt conveyor for lighter products
- Fully insulated to maintain a consistent heat
- Bottom air flow heat transfer to enhance shrinking
- High efficiency heating elements for long lasting heat power
- Automatic cool down timer to extend the life of the heating element
- Optional Console leg kit w/casters and levelers for mobility and safety

Clamco Table-Top Heat Shrink Tunnel

Model	Price
820MB Table-Top Shrink Tunnel 110V/2100W	\$2,600.00
820HD Table-Top Shrink Tunnel 220V/4000W	\$3,380.00
Console Leg Kit with Casters & Levelers	\$615.00
FOB: Factory, Cleveland, Ohio	

CLAMCO

AUTOMATIC L-BAR SEALER



Clamco 6700GLX Automatic L-Bar Sealer for Shrink Wrap Packaging

The Clamco 6700GLX Automatic L-Bar Sealer has the advantages you need—an enhanced microprocessor PLC control system, touch screen interface and I/O diagnostics, memory for up to 20 package sizes, interface tunnel controls, motorized film unwind, hot knife sealing system, self-adjusting scrap take-up wheel, microperforators for uniform air evacuation--and much more. All resulting in an automatic L-bar sealer with outstanding speed, throughput and performance to maximize productivity and profits.

SPECIFICATIONS

- Speed: up to 40 packages/min
- Maximum Film Width: 23"
- Maximum Product Height: 8"
- Hot Knife Sealing System: 18" x 23" seal area
- Machine Dimensions: 69" Lx 50" Wx 51"H
- Machine Weight: 370 lbs (168 kg)
- Electrical Requirements: 120V, 15A, 2,100 w
- Air Requirements: 80 psi, 5 cfm

Base Price - \$31,420.00

CALL FOR A FREE CONSULTATION & QUOTE



West Coast Plastics Equipment Inc., 623 S. Hindry Ave., Inglewood, CA 90301 (new address)
 CALL TO ORDER 800-392-8569 / 310-215-3186 or FAX 310-642-0468 01/17
 Web Page: www.wcpsealers.com E-Mail: sales@westcoastplastics.com



120C/240C COMBO SHRINK SYSTEM



The Clamco 120 Combo Shrink System provides increased productivity and years of trouble free operation.

The Clamco 120C/240C Combo Shrink System combines the L-Bar sealer and shrink tunnel for packing, sealing, and shrinking products. The sealer and tunnel have a common frame and base that allows for a quick set-up, alignment, and product transfer by matching the sealer with the tunnel. The Clamco Combo system includes standard features such as a unitized package tray and a film cradle with a pinwheel perforator to assist in the fast and efficient placement of the product into the film.

The sturdy design of the Clamco Combo provides the framework for greater productivity and insures consistently strong seals. The digitally temperature controlled tunnel provides for consistent shrink. The use of integrated application specific controls allow for easy and fast operator set-up and provides for years of trouble free operation.

The Clamco 120C refer to 120V and 2100W electrical, which is an excellent choice for an entry-level machine. If you require a more robust system, the Clamco 240C is a 220V machine with a full 4,000 watts of tunnel power and a motorized Power Take Away system. The Combo Series includes standard feature and unique advantages at a comparatively lower price, considered the best value in its category.

Features and Benefits:

- Seal temperature control provides repeatability of seal performance
- Dwell control provides additional flexibility for utilizing a wide range of films
- Heavy duty magnetic hold down for consistent seal pressure
- Easy-to-use operator controls for fast and easy set-up
- Quick adjustment facilities centering of the seal on the product
- 2100-watt (120C) or 4000-watt (240C) digitally controlled heat tunnel with 360 degree air circulation
- Adjustable airflow and variable tunnel conveyor speed to enhance shrink performance
- Automatic cool down and shutoff extends the life of the machine
- Adjustable unitized package tray and film cradle with pinwheel perforator
- Film cradle can accommodate up to 20" wide roll of film
- Tunnel curtain design minimizes heat loss and maintains tunnel temperature consistency
- Robust design with a welded steel frame and heavy duty seal arm
- Designed to meet CE requirements

Options & Accessories:

- Power take away conveyor for 120C
- Variable speed power take-away conveyor
- Hot knife sealing system for 240C
- Heavy duty locking casters
- 12" opening tunnel (220 Volt only)
- Short frame - 74" long (1880mm)

Specifications:

- Film capacity: 20" (508mm)
- Wattage: 2,100 watt tunnel
- L-Bar seal area: 16"W x 20"L (406mm x 508mm)
- Weight: 370 lbs. (168 kg)
- Machine Dimensions: 24"L x 91"W x 52"H (610mm x 231mm x 1321mm)
- Max Product Height: 6" (152mm)
- Tunnel Chamber Dimensions: 16"L x 20"W x 8"H (406mm x 508mm x 203mm)
- Conveyor Speed: 1-25 FPM
- Electrical: 120V, 19.5 amps, 50/60 Hz

Model #	Description	Price
120C	Unitized Shrink System 16" x 20" Seal area with 16" W x 8"H shrink tunnel - 120 volt	\$6,560.00
240C	Unitized Shrink System 16" x 20" Seal area with 16" W x 8"H shrink tunnel - 220 volt	\$7,620.00
Accessories:		
PTA	Power Take Away Conveyor for 120C (standard on 240C)	\$1,040.00
946-000015	Hot Knife Seal System for 240C combo shrink system only	\$2,020.00
948-000011	Service Parts Kit	\$195.00
5771	Scrap Take-up Wheel	\$1,690.00
FOB: Cleveland, Ohio		





HEAVY DUTY L-BAR SEALERS

The Clamco heavy duty L-bar sealers are available in several sizes—4L, 6L, and the extra large 8L for packaging and sealing a variety of products. Clamco heavy duty L-bar sealers can be used with a wide range of films due to their precise temperature and speed controls. These dependable L-bar sealers are equipped with a sealing arm that works manually, pneumatically, or with a motor. The robust design of the Clamco systems provides the framework for greater productivity and ensures consistently strong seals.

The use of integrated application-specific controls allow for easy and fast operator set-up and provide years of trouble-free operation. The Clamco L-bar sealers reduce the need for a hot knife seal bar with a unique seal wire temperature control system. In addition to the temperature control, the Clamco L-Bar sealer has dwell control for continued seal time under pressure, and speed control for the product power take-away conveyor. The Clamco system also has a convenient adjustable height control for the power take-away conveyor to provide smooth product transfer.

The Clamco heavy duty L-bar sealers are 24/7 machines that minimize maintenance, provide consistently strong seals and can be used with a wide range of films.

The Clamco heavy duty L-bar sealer is made in the USA and includes a 3-year limited warranty.



Operating Features

- Power take-away conveyor for automatically transporting the product from the seal area
- Automatic closing seal bar arm (optional)
- Heavy duty frame construction provides 24/7 operation
- Easy-to-use operator controls enhance operator effectiveness
- Independent dwell control allows flexibility for utilizing a wide range of films

Sealing Features

- Large dual magnetic hold down ensures a consistent seal pressure
- Height adjustable, heavy duty seal head with stainless steel film clamps
- Unique temperature control provides consistent seals and longer wire life
- Spring tension adjustment enhances seal arm counterbalance and return speed
- Pin perforation wheels allow for ventilation and excellent shrink

Set-up Features

- Cycle delay sets the time between cycles in automatic mode (optional)
- Lower Film Cradle gives the machine a smaller footprint

Safety Features

- Cycle start button for operator safety
- Locking casters for safety and stability
- CE compliant design for enhanced troubleshooting

Need Shrink Film?
See Page 38

Model	Clamco 4L	Clamco 6L	Clamco 8L
Seal length (end)	19"	27.5"	39"
Seal length (side)	22"	33"	50"/69"/88"
Maximum film width	24"	32"	52"
Overall length	35"	60"	87"/101"/119"
Overall width	27.5"	36"	51"
Overall height	36"	36"	41"
Electrical	220V, 10A, 1Ph	220V, 10A, 1Ph	220V, 20A, 1Ph
Shipping weight	450 lbs	600 lbs	1300 lbs
Price	\$7,105	\$9,085	call





HEAVY DUTY SHRINK TUNNELS



Clamco 6T Heavy Duty Heat Shrink Tunnel



Clamco 6Tx2 Extra Large Heat Shrink Tunnel

The **Clamco 4T and 6T Heavy Duty Heat Shrink Tunnels** are engineered with many features to offer a combination of performance and dependability. Due to their precise temperature and speed controls, Clamco heavy duty tunnels are perfect for shrinking a wide range of films, from the lightest polyolefin to the toughest polyethylene films. Combine this durable shrink tunnel with the heavy duty Clamco L-Bar Sealer to create a complete shrink system.

The tunnel features include digital temperature control for precise shrink wrap performance, adjustable airflow and variable tunnel conveyor speed. These tunnels are equipped with long-life blowers and 360° airflow to further enhance control of film shrink. The automatic cool down and shut off extend the life of the tunnel. The tunnel curtain design and tunnel insulation minimize heat loss, maintain tunnel temperature consistency and keep outside tunnel panels cooler. The tunnel conveyor features 1.5-inch roller spacing that works well with large to small products and quick change live/dead rollers. The Clamco 4T and 6T tunnels operate 24/7 with unique microprocessor controls for consistent shrink on a variety of applications. Count on Clamco heavy duty shrink tunnels for dependable performance.

The **Clamco Heavy Duty Extra Large Heat Shrink Tunnels** feature extra length when compared to our standard heavy duty tunnels and are perfect for packing, sealing, and shrink wrapping larger size products. The extra length can also accommodate longer shrink time at a faster pace or film that requires a lower shrink temperature. Due to their precise temperature and speed controls, Clamco extra length tunnels are perfect for shrinking a wide range of films, from the lightest polyolefin to the toughest polyethylene films. Combine this durable shrink tunnel with the heavy duty Clamco L-Bar Sealer or our versatile 6800CS Side Sealer to create a complete shrink system.

These high-performance tunnels are engineered with 360° airflow and two blowers to further enhance control of film shrink. Optional dual zone controls can be used to set two different temperature zones in the tunnel chamber. Optional independent air velocity control allows the user to adjust the speed of each blower to optimize airflow in the tunnel, especially important at high speeds. Clamco extra large tunnels are built with automatic cool down and shut off to extend the life of the tunnel. The tunnel curtain design and tunnel insulation minimize heat loss, maintain tunnel temperature consistency and keep outside tunnel panels cooler. Optional external fans help cool the product and complete the shrink cycle. These Clamco tunnels are heavy-duty 24/7 machines with unique microprocessor controls for consistent shrink on a variety of applications. Count on Clamco extra large shrink tunnels for dependable performance.

Clamco Heat Shrink Tunnels are made in the USA and include a 3-year limited warranty.

Model	4T	6T	4Tx2	6Tx2	8Tx2	8Tx3
Tunnel opening width	15.5"	25.5"	15.5"	25.5"	46"	46"
Tunnel opening height	9" (13"opt)	13.5" (17.5"opt)	9" (13"opt)	13.5" (17.5"opt)	13.5" (17.5"opt)	13.5" (17.5"opt)
Tunnel inside height	11" (15"opt)	15.5" (19.5"opt)	11" (15"opt)	15.5" (19.5"opt)	15.5" (19.5"opt)	15.5" (19.5"opt)
Tunnel inside length	26"	34"	50"	66"	66"	99"
Conveyor speed (max)	125 ft/min	125 ft/min	125 ft/min	125 ft/min	125 ft/min	125 ft/min
Electrical requirements	230V,20A,3ph	230V,20A,3ph	230V,20A,3ph	230V,20A,3ph	230V,20A,3ph	230V,20A,3ph
Tunnel Heating Power	6KW	9KW	12KW	18KW	24KW	36KW
Price	\$8,225	\$11,110	\$13,020	\$17,180	call	call



CLAMCO 4C - 6C COMBO SHRINK SYSTEM

Heavy duty combo shrink wrap machines - The Clamco 4C and 6C combo shrink wrap machines combine a heavy duty L-bar sealer and shrink tunnel for packing, sealing, and shrink wrapping a variety of products. Clamco combo shrink wrap systems can be used with a wide range of films due to their precise temperature and speed controls. These combo shrink wrap machines come with a standard power take-away system and are available with a sealer arm that works manually, pneumatically, or with a motor.

Built for performance - The robust design of the Clamco systems provides the framework for greater productivity and ensures consistently strong seals. The digitally temperature controlled tunnel provides for consistent shrink. The use of integrated application-specific controls allow for easy and fast operator set-up and provides for years of trouble free operation.

Industry leading durability and technology - The Clamco 4C and Clamco 6C combo machines are heavy duty shrink systems engineered for 24/7 use. Designed to minimize maintenance and provide consistent strong seals they can be used with a wide range of films. The Clamco seal system eliminates the need for a hot knife seal bar by utilizing a unique seal wire temperature control system. The Clamco system has a single adjustable height control for the product take-away and tunnel conveyor to deliver smooth product transfer. The height of the tunnel chamber is adjustable, increasing shrink efficiency for short products. Additionally, Green Mode allows for the Clamco 4C and Clamco 6C to slow down and conserve energy when the machine remains idle for several minutes.

Clamco 4C and 6C Combo L-bar sealers and shrink tunnels are made in the USA and include a 3 year limited warranty.



L-Bar Sealer Features

- Heavy duty dual magnetic hold down ensures consistent seal
- Quick conveyor height adjustment facilitates centering of the seal on the product
- Adjustable package tray and film cradle with pinwheel perforator

Shrink Tunnel Features

- Power Take-away System enhances technician productivity
- Live/dead roller system allows the use of a wide variety of films
- Green Mode allows the system to slow down and conserve energy when not in use
- Digitally controlled tunnel temperature with 360° air circulation for top performance
- Adjustable tunnel chamber height increases shrink efficiency
- Side and bottom dampers for optimal air flow adjustment

Operating Features

- Convenient scrap collection reduces clean-up
- Easy-to-use operator controls require minimal training
- Low film cradle for easy access when changing rolls
- Automatic cool down and shut off function extends the life of the machine

Safety Features

- Designed to meet CE safety requirements
- Adjustable foot pads to ensure operator safety and machine stability
- Emergency stop button

Model	Clamco 4C Combo	Clamco 6C Combo
Seal length (end)	18.5"	27.5"
Seal length (side)	21.5"	33"
Film width (max)	24"	32"
Tunnel opening width	15.5"	25.5"
Tunnel opening height (std./opt.)	9"/13"	13.5"/17.5"
Tunnel inside height (std./opt.)	11"/15"	15.5"/19.5"
Tunnel inside length	26.5"	34"
Tunnel power	6,000 watts	9,000 watts
Overall dimensions	84"L x 31"W x 57"H	110"L x 39"W x 62"H
Electrical Requirements	220V, 20 amp, 3 Ph	220V, 30 amp, 3 Ph
Weight	666 lbs	970 lbs
Shipping weight	904 lbs	1225 lbs
Warranty	3 years	3 years
Price	\$9,995	\$13,425





CLAMCO 6800CS SIDE SEALER

The Clamco 6800CS is an economical intermittent motion, automatic side seal shrink wrapper. Compared to traditional automatic L-bar sealers, the 6800CS side sealer offers a unique advantage: it is capable of packaging products of virtually any length and at a high rate of speed. Using standard polyolefin or polyethylene center-folded shrink film, the versatile 6800CS side sealer wraps up to 4200 packs per hour.

Excellent for a wide variety of package sizes, the 6800CS will accommodate parcels measuring 15.75" wide by 7.85" high, (by almost any length) - down to a package the size of a small book. The side sealer features an adjustable film inverting head, low, easy-to-reach film cradle, and accessible film adjustment controls that enable the operator to set-up and begin production quickly and easily.

The intuitive, easy-to-navigate user interface may be learned quickly for operators of average skill level. The digital display indicates key packing statistics, including: production rate, packaging efficiency, 20 program memory and more. Twin doors provide easy access to all functional areas.

User benefits

- Temperature controlled system provides repeatable, strong seals
- Power take-away and tunnel conveyors share a common height adjustment to provide for smooth product transfer
- Heavy-duty design for 24x7 productivity, with minimal aintenance
- Scrap collection area for reduced cleanup time clean-up time
- Live/dead roller system allows the use of a wide variety of films
- Dwell control provides additional flexibility
- Powerful magnetic hold down for consistent trim seal pressure

Set-up benefits

- Automatic seal centering on both the side seal and the cross seal, for a cleaner, more attractive package
- Automatic product length detection allows individual or multiple products to be wrapped
- Quick changeover and 20-program memory enables machine set-up in fewer than five minutes
- Low film cradle with inverted head for easy film loading

Operating benefits

- Seals packages of virtually any length - quickly and efficiently
- Integrates easily with shrink tunnel
- Use with a wide variety of films
- Twin door access to key functional areas
- PTFE-coated side seal blade works with standard shrink films (up to 120 gauge polyolefin)
- Trim take-up spool keeps work area clean
- On-board troubleshooting menu

Safety benefits

- Fully enclosed mechanical areas ensure operator safety
- Smooth and quiet operation reduces noise
- Compliance with CE regulations ensures improved safety
- Easy-to-reach emergency shut-off

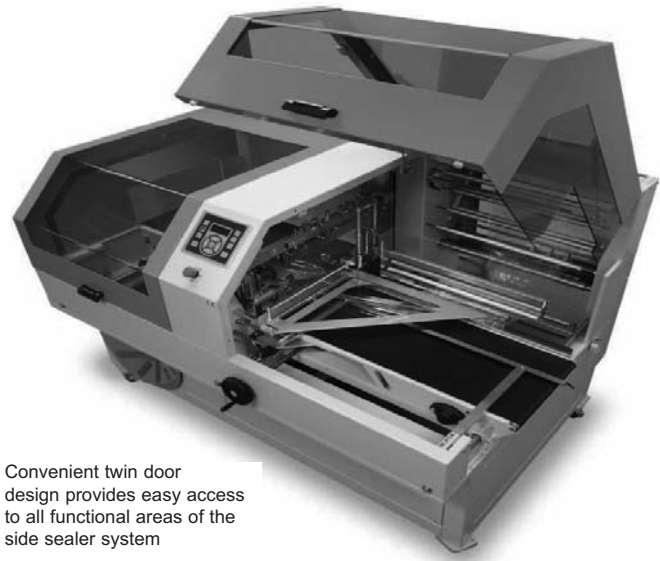

Convenient twin door design provides easy access to all functional areas of the side sealer system

Options and Accessories

- Polyethylene cross seal bar for 0.6–3.0 mil. polyethylene film
- Stainless steel frame for applications in the food industry
- Print registration for pre-printed film
- Safety photocell prevents cross seal bar from contacting product

Technical Specifications

Conveyor Speed:25–95 ft/min
Production capacity:up to 70 cycles per minute
Cross seal bar width:9.75"
Maximum product width:15.75"
Maximum product height:7.85"
Maximum product length:unlimited
Maximum film width:23.5"
Maximum film roll diameter:13.75"
Electrical requirements:220 Volt, 7 Amps, 3 Phase
Air requirement:90 psi
Shipping weight:1,800 lbs
Machine size (w x d x h)86" x 61" x 61"

West Coast Plastics Equipment Inc., 623 S. Hindry Ave., Inglewood, CA 90301 (new address)

CALL TO ORDER 800-392-8569 / 310-215-3186 or FAX 310-642-0468 01/17

Web Page:www.wcpsealers.com E-Mail:sales@westcoastplastics.com





FW-350TC & FW-400F FLOW WRAPPERS

Horizontal Form, Fill, and Seal Machine



FW-350TC Flow Wrapper

Technical Information (FW-350TC):

- Speed : up to 60 bags per minute
- Bag Length : 3¼" to 9¾"
- Max Product Height : 2¼"
- Max Product Width : 4¼"
- Standard infeed conveyor length: 2.5 feet
- Extended infeed conveyor length: 4 feet
- Vertical distance from base to infeed conveyor: 15"
- Machine Dim. (L x D x H): 53¼" x 31½" x 35½"
- Machine Footprint: 40" L x 25" D
- Electrical: 220V, 1-ph, 15A

The **Packaging Aids Corp. FW-350TC Flow Wrapper** is a horizontal form, fill, and seal machine that's ideal for suppliers of products that must be packaged individually. This may include candies and confections, bakery, electronics, hardware, and medical products. This entry level machine is a high performance packaging system in a small footprint (7 square ft). It's small enough to fit on a tabletop! The FW-350TC is the perfect choice for new applications or for increasing your capacity. It can achieve speeds of up to 60 packages per minute. Settings can be easily changed to accommodate various package sizes - up to 9 3/4" long, 2 1/4 " high, and 4 1/2" wide.

Product is fed into the machine either manually or automatically. The attached product feeder indexes items forward and encloses them into a formed tube of film. This web of material is then sealed using a "fin seal". The enfolded product is then further indexed to be end sealed and cut off in a continuous process. The result is a neatly wrapped finished product. This unit features fast set-up, changeover flexibility, and ease of use. The FW-350TC is fitted with constant-heat sealing bars which make it suitable for sealing polypropylene, co-extruded, laminated, lacquered and various complex films. Options Include: Photocell for indexing pre-printed films, In-line printer, Gas Flush, Gusset former, Date Coder and Stainless Steel Construction. The FW-350TC will work with complementary equipment including: counting systems, conveyor belt feeder systems and take away conveyor belts.

For higher production needs, the versatile **FW-400F** automatic horizontal form, fill, and seal machine (flow wrapper) is ideal for packaging individual products at speeds up to 120 bags per minute. The product may be fed into the machine either manually or automatically. The FW-400F can seal polypropylene, co-extruded, laminated, lacquered, and other complex films.

Standard Features:

- Adjustable bag former to accommodate various product dimensions
- Single film roll holder with adjustment for easy centering of film
- 5' in-feed conveyor with adjustable width for various product dimensions
- Discharge conveyor
- Precision photocell for indexing preprinted film
- End of film detection to stop machine automatically
- Safety covers to prevent operator access to moving parts
- Digital display to indicate bag length, speed, and bag count
- Dual fin seal wheels
- Independent temperature controllers for fin and end seals
- Painted machine frame
- Stainless steel construction of product contact areas
- Zig-zag end seal cut for easy opening of package



FW-400F Flow Wrapper

Technical Information (FW-400F):

- Speed : up to 120 bags per minute
- Bag Length : 3" to 12½"
- Max Product Height : 2"
- Max Product Width : 4¾"
- Max Film Width: 16"
- Film Max Diam: 12½" O.D. Film Core: 3" I.D.
- In-feed Conveyor Length: 5'
- Machine Dim. (L x D x H): 112" x 32" x 60"
- Electrical: 230V, 1-ph, 15A

Model

Model	Price
FW-350TC Horizontal Flow Wrapper (painted)	\$22,110.00
FW-350TC-SS Horizontal Flow Wrapper (stainless steel)	\$25,795.00
FW-400F Horizontal Flow Wrapper (painted)	\$33,110.00
FW-400-SS Horizontal Flow Wrapper (stainless steel)	\$38,745.00

Options

Stand for 350T (painted)	\$895.00
Stand for 350T (stainless steel)	\$1,270.00
Date/Lot Code Printer for FW-350T & FW-400F	\$4,190.00
Round Hang Hole, Straight Cut Knife w/ tear notch for FW-400F	\$3,150.00
Gas Flush Capability for FW-350T & FW-400F	\$1,820.00
FOB: San Rafael, CA	



West Coast Plastics Equipment Inc., 623 S. Hindry Ave., Inglewood, CA 90301 (new address)

CALL TO ORDER 800-392-8569 / 310-215-3186 or FAX 310-642-0468 01/17

Web Page: www.wcpsealers.com E-Mail: sales@westcoastplastics.com

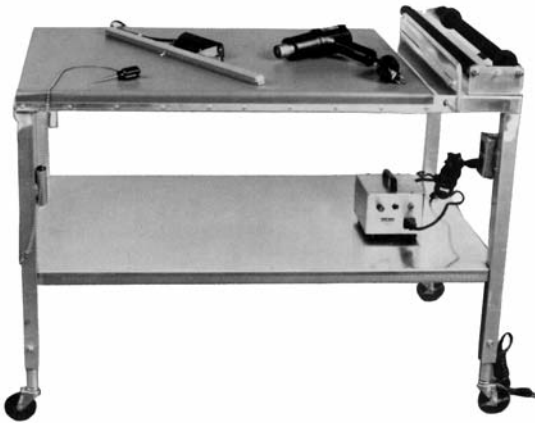

Heat Seal Model MWSBT-I-18 Timed Impulse 18" Magic Wand Portable Shrink Wrap System with Table - shown with optional adjustable height legs.

Model #	Description	Price
Manual Impulse Units		
MWS-M-18	Manual Impulse 18" M.W. System	\$624.00
MWS-M-24	Manual Impulse 24" M.W. System	\$637.00
MWST-M-18	Manual Impulse 18" M.W. System w/Table	\$1,187.00
MWST-M-24	Manual Impulse 24" M.W. System w/Table	\$1,200.00
Timed Impulse Units		
MWS-I-18	Timed Impulse 18" M.W. System	\$877.00
MWS-I-24	Timed Impulse 24" M.W. System	\$923.00
MWS-I-36	Timed Impulse 36" M.W. System	\$950.00
MWST-I-18	Timed Impulse 18" M.W. System w/Table	\$1,445.00
MWST-I-24	Timed Impulse 24" M.W. System w/Table	\$1,481.00
MWST-I-36	Timed Impulse 36" M.W. System w/Table	\$1,653.00
Options		
GUN	Milwaukee Heat Gun	\$40.00
HG115V	Heavy Duty Master Hot Air Gun	\$184.00
FOB: Cleveland, Ohio		

The **Magic Wand Portable Shrink Wrap System** is ideal for shrink wrapping large or odd shaped products. It features a hand-held sealing wand, power pack, 24" x 36" sealing pad and film cradle with separator. The Hot Air Gun is optional. The system is also available with a 28"W x 44"L adjustable height sealing table with locking casters. The Magic Wand comes with either manual or timed impulse sealing.

Need Shrink Film?

See Page 38

TABLE-TOP FOOD WRAPPER MODELS

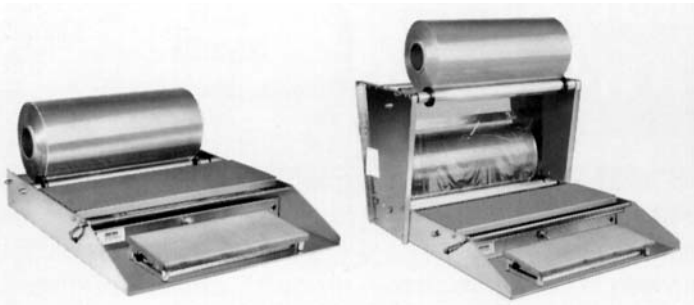

Heat Seal Table-Top Food Wrappers - Model 600-A (left) one-roll basic unit with rollers and Model 800-A (right) two-roll capacity with rollers.

For reliability, for durability, for functional quality and design integrity, **Heat Seal Table-Top Food Wrappers** give you maximum value in any packaging operation. Heat Seal Table Model Wrappers earn daily the reputation that has made them the favorite in supermarkets, deli's, print shops, or wherever a quality packager is needed. These units feature tough aluminum and stainless steel construction with all stainless wrapping surface for quick, easy clean-up. Each wrapper is equipped with extra large rubber feet to prevent sliding on any counter surface. And all feature the solid state controlled hot rod cutoff bar and standard 6" x 15" hot plate (6" x 9" hot plate on Mini units) with a non-stick Teflon cover. Every Heat Seal Wrapper is UL listed and USDA approved.

Model No.	Film Capacity	Hot Plate	Price
500-A Mini	1-Roll 12" w/Roller	6" x 9"	\$262.00
500-A	1-Roll 18" w/Roller	6" x 15"	\$345.00
600-A	1-Roll 20" w/Roller	6" x 15"	\$375.00
600A-24	1-Roll 24" w/Roller	8" x 15"	\$579.00
600A-30	1-Roll 30" w/Roller	10" x 30"	\$852.00
600A-36	1-Roll 36" w/Roller	10" x 36"	\$888.00
625-A	1-Roll 18" w/Axle	6" x 15"	\$384.00
625-A24	1-Roll 24" w/Axle	8" x 15"	\$593.00
625-A Mini	1-Roll 12" w/Axle	6" x 9"	\$340.00
800-A	2-Rolls 20" w/Rollers	6" x 15"	\$503.00
825-A	2-Rolls 18" w/Axles	6" x 15"	\$531.00
850-A	3-Rolls 20" w/Rollers	6" x 15"	\$557.00
875-A	3-Rolls 18" w/Axles	6" x 15"	\$578.00
FOB: Cleveland, Ohio			

NEW!! The Heat Seal Extra Wide Table Sealer Models 600A-24, 625A-24, 600A-30, 600A-36 for larger applications. The 600A-24 and 625A-24 are available with an 8" x 15" hot plate and 24" wide film capacity. The 600A-30 has a 10" x 30" hot plate and 30" wide film capacity. The 600A-36 has a 10" x 30" hot plate and 36" wide film capacity.

Heat Seal Table-Top Food Wrappers are available in 1, 2, or 3 roll units. You may also select the film roll mounting system which best suits your individual needs: Axle mounting for more efficient film usage, or Roller mounting for faster, easier roll loading.

It's Portable! All Heat Seal Food Wrappers are easy to move--and that's important when limited counter space means your wrapping area must sometimes be used for other purposes.





P.A.C. PNEUMATIC BARRIER SEALERS

The **PAC Barrier Bag Sealer PB/PVB Series** are heavy-duty, pneumatically operated sealers (PB) and vacuum sealers (PVB). The pneumatic operation gives ease of use, as well as much more consistent performance from seal to seal. The heated upper jaw is temperature adjustable up to 550°F by an analog controller. It is ideal for MIL spec barrier materials, coated paper, film and foil laminated bags. The PAC Barrier Series comes standard with pivoting head, machine stand with rollers, safety jaw close, and independent control console. The standard seal width is 3/4" with seal lengths from 12" up to 36".

The PVB Vacuum Barrier Sealers have all the same features as the standard PB Barrier Sealers as well as a vacuum system with 1/4 HP vacuum pump, gas flush and dual retractable stainless steel nozzles.

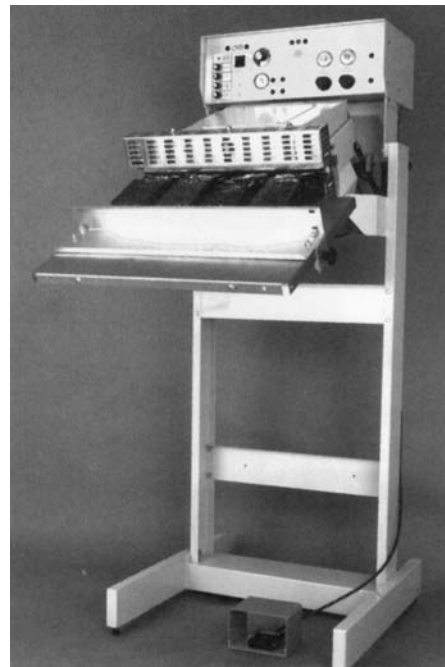

P.A.C. Model PV-B18 Vacuum Barrier Sealer

P.A.C. VACUUM BARRIER SEALERS

Model No.	Seal Length	Price
PVB-G12	12"	\$8,255.00
PVB-G18	18"	\$8,495.00
PVB-G24	24"	\$9,105.00
PVB-G30	30"	\$9,360.00

P.A.C. STANDARD BARRIER SEALERS (no vacuum)

Model No.	Seal Length	Price
PB-G12	12"	\$5,880.00
PB-G18	18"	\$6,095.00
PB-G24	24"	\$6,630.00
PB-G30	30"	\$7,145.00
PB-G36	36"	\$7,490.00

Options:

Temperature Controller with Digital Readout	call
PAC Workshelf	\$623.00
Bag Support for Workshelf	\$257.00
Bag Stretcher (PVB)	\$930.00
Locking Swivel Casters	\$305.00
Stainless Steel Frame	\$1,835.00
FOB: San Rafael, CA	

ECONOMY CONSTANT HEAT SEALERS



Model WCK-300

The **TEW Economy Constant Heat Sealers** work very well on cellophane bags, foil laminate pouches, kraft paper poly bags and other supported laminates. The bare metal jaws will not work well on plain poly bags and other highly meltable materials. The 1/2" wide jaws make a knurled "cross-hatched" pattern seal for tight closure of the bags. There is now also available a 12" model with horizontally serrated jaws 1/2" wide.

Manually operated by foot-pedal, they feature a 50-200°C thermostat temperature controller and an adjustable workshelf. The TEW Economy Constant Heat Sealers are easy to assembly, easy to operate, easy to maintain with no wearable parts, and easy on the budget. One year factory limited warranty.

WCPE Model No.	Mfgs. Part No.	Seal Length	Price
WCK-200	THS-200	8" (200mm)	\$375.00
WCK-300	THS-300	12" (300mm)	\$420.00
WCK-300S (serrated jaws)	THS-300S	12" (300mm)	\$420.00
WCK-400	THS-400	16" (400mm)	\$450.00
FOB: Inglewood, CA.			



West Coast Plastics Equipment Inc., 623 S. Hindry Ave., Inglewood, CA 90301 (new address)
CALL TO ORDER 800-392-8569 / 310-215-3186 or FAX 310-642-0468 01/17
Web Page: www.wcpsealers.com E-Mail: sales@westcoastplastics.com

VACUMASTER SKIN PACKAGING



Vacumaster Skin Packager
Model 1824T

The **Vacumaster Skin Packaging System** by Clamco provides showcase appeal, product protection and reduced packaging costs for your products. Products are kept secure, clean, visible and unbroken, vacuum sealed onto the board by plastic film. For small and large packages up to 30" x 36". Retail display packs can be die cut from individual master boards.

The Vacumaster features the patented, energy efficient, ThermOpulse "Heat On Demand" heating system. It heats instantly at the beginning of each cycle, and cools immediately at the end of the cycle - there's no wasted energy.

The Vacumaster is a stationary oven machine and takes about half the floor space of competitive traveling oven units, and it has no moving parts to wear out. You get precise control in a space-saving stationary oven that eliminates the danger and mechanical failure of moveable ovens or those with heat blocking devices.

Simpulse™ Cut-off, standard on all Vacumaster models, dramatically increases production efficiency. The cut-off automatically separates the finished package from the continuous roll of film, and the machine is ready for the next cycle.

The uniquely efficient Vacumaster Skin Packaging Machine will work with all skin packaging films of any practical gauge. All units require 80 psi @ .7 cfm compressed air and run on 220V 3-phase electrical.

Model #	Description	Max. Film Width	Max. Sheet Size	Max. Product Height	Price
1824T	Vacumaster Skin Packager	20"	18" x 24"	8"	\$9,055.00
2430T	Vacumaster Skin Packager	26"	24" x 30"	8"	\$10,740.00
2436T	Vacumaster Skin Packager	26"	24" x 36"	8"	\$11,475.00
3036T	Vacumaster Skin Packager	32"	30" x 36"	8"	\$12,840.00
RDC30	Vacumaster Roller Die Cutter				\$13,895.00

FOB: Factory, Cleveland, Ohio.



THERMO-JAW & MOTOR-JAW

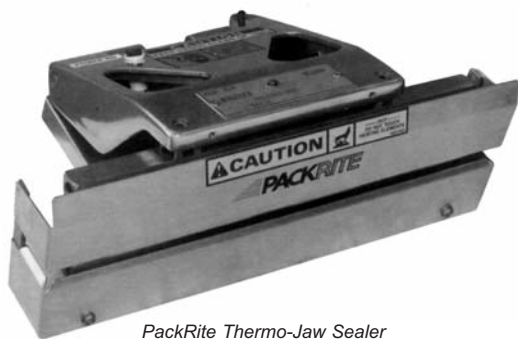

PackRite Thermo-Jaw Sealer

The **PackRite Thermo-Jaw Sealer** is an economical, easy-to-use jaw-type sealer operated by foot-pedal. Heavy duty heating elements and brass sealing bars in the upper and lower jaws provide uniform and sufficient penetration to achieve a high quality, airtight seal. The machine's adjustable thermostat permits accurate temperature control 200-500°F, further assuring superior seal integrity.

The Thermo-Jaw is designed for use on a wide variety of heat-sealable materials, including cellophane, polycel, glassine, laminates, overcap labels, polypropylene, krafts, foils and even MIL Spec materials.

Three types of sealing impressions are available: flat smooth seal, wide vertical crimp with 16 vertical serrations per inch, and wide horizontal crimp with 12 horizontal serrations on the width. The Thermo-Jaw comes with either 3/4" wide or 1" wide seal bars, just specify which one you need. A 16-digit embossed code dating bar is also available as an option (on 1" wide seal bars only).

The **PackRite Thermo Motor-Jaw Sealer** is a motorized version of the Thermo-Jaw. It is a versatile, motorized heat sealing machine that provides either continuous automatic or intermittent stop/start cycling with the flip of a switch. In the automatic mode, up to 30 packages per minute can be sealed. In the intermittent mode, the machine is controlled by footswitch. The dwell option allows the user to adjust the seal time for the various types of materials.

PackRite Thermo-Jaw Sealers	Price
Thermo-Jaw Sealer 12" Jaws	\$685.00
Thermo-Jaw Sealer 15" Jaws	\$705.00
Vertical Mounting Bracket	\$140.00
Universal Sealer Stand	\$285.00
3/8" Hole Punch	\$160.00
Embossing Code Dating Bars	\$200.00
PackRite Thermo Motor-Jaw Sealers Price	
Thermo Motor-Jaw with Dwell Control-12"	\$2,300.00
Thermo Motor-Jaw with Dwell Control-15"	\$2,375.00
Universal Sealer Stand	\$285.00
Embossing Code Dating Bars	\$200.00

FOB: Racine, Wisconsin





AUDION FUTURA PORTABLE SEALERS



Audion Futura Poly Sealer

The **Futura Portable Hand Sealers** are made by Audion, a name that has been an industry standard for quality sealers for over 40 years. They come in three models to meet varying job requirements. Each model can come with mounting brackets & foot pedal for table top installation (see image below left) or without for hand held use. No special stand and no screws are necessary for table top/workbench mounting.

The **Futura Poly** Model with the sealing jaw covered with teflon coated fiberglass, is designed for sealing polyethylene, PVC, pliofilm, saran and other transparent plastics. The teflon cover keeps the material from sticking to the heating element for making the 1/8" wide by 6" long seal. The bottom jaw contains resilient silicone rubber.

The **Futura Poly Twin** Model has sealbars on both the top & bottom jaws. It makes a 1/8" wide by 6" long seal of the same style as the Futura Poly Model but is able to seal thicker and harder to seal materials.

The **Futura Barrier** Model has two heated 9/16" wide by 6" long bare metal flat jaws (top and bottom) and three temperature settings for mil spec barrier materials.

The **Futura Cello** Model has two heated 9/16" wide by 6" long serrated jaws (top and bottom) for crimp sealing materials such as cellophanes, waxed paper, header labels, foils, laminations. The heat is controlled by a switch with three temperature settings.



Audion Futura Cello Sealer with Mounting Hardware

Model	No Mounting Hardware	With Mounting Hardware
1F02100 Poly Sealer	\$150.00	\$210.00
1F01100 Poly Twin (dual seals)	\$195.00	\$255.00
1F04100 Barrier Sealer	\$195.00	\$255.00
1F03100 Cello Sealer	\$195.00	\$255.00
Parts	Price	
8F02502 Top & Bottom Housing Set	\$75.00	
2F02014 Sealing Rubber - 3 pack	\$16.00	

HEAT SEAL

KWIK CONSTANT HEAT "HOT JAWS"

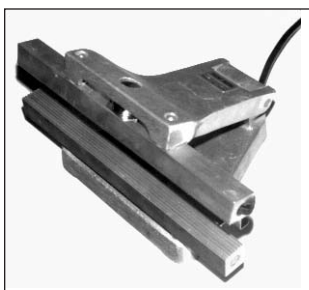

Kwik C12-Serrated Jaw Sealer

Kwik Hot Jaw Sealers by Heat Seal come with a 1" wide seal and a temperature control thermostat to give the operator flexibility for use with a wide range of materials. The Kwik sealers are foot-pedal operated and come standard with a foot pedal. The Sealer is mounted on a table or workbench, while the foot pedal is attached to the floor. Also available is the optional stand with integral foot pedal to make the unit a stand-alone workstation.

The Kwik Hot Jaw Sealers come in three models: Model C-Serrated - bare metal jaws with horizontal serrations for Cellophanes; Model C-Flat - with bare flat jaws for most barrier materials; Model P-with 1/4" wide teflon covered jaws for polyethylene & polypropylene. The Model C-Flat units can be ordered with adhesive teflon covers for use with polyethylene materials.

Model C-Flat	Price	Model C-Serrated	Price	Model P-Poly	Price
C8-Flat	\$342.00	C8-Serrated	\$342.00	P8	\$330.00
C10-Flat	\$354.00	C10-Serrated	\$354.00	P10	\$347.00
C12-Flat	\$377.00	C12-Serrated	\$377.00	P12	\$370.00
C14-Flat	\$403.00	C14-Serrated	\$403.00	P14	\$392.00
C16-Flat	\$430.00	C16-Serrated	\$430.00	P16	\$422.00
C18-Flat	\$455.00	C18-Serrated	\$455.00	P18	\$446.00
C24-Flat	\$515.00	C24-Serrated	\$515.00	P24	\$506.00
Optional Stand for Kwik Sealer					\$247.00
Teflon Cover for Model C-Flat & P-Poly					\$30.00

NOTE: Model number indicates length of seal in inches. FOB: Cleveland, OH



West Coast Plastics Equipment Inc., 623 S. Hindry Ave., Inglewood, CA 90301 (new address)
CALL TO ORDER 800-392-8569 / 310-215-3186 or FAX 310-642-0468 01/17
Web Page: www.wcpsealers.com E-Mail: sales@westcoastplastics.com

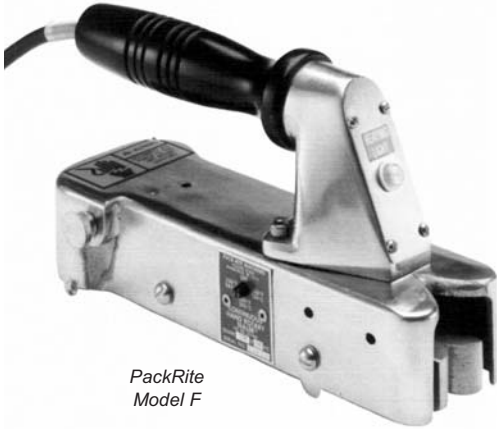

PackRite
Model F

The **PackRite Model F & G Rotary Sealers** are hand-held, non-motorized units specifically for sealing bulky or large supported Mil-Spec materials. Not for use on polyethylene. The material is fed continuously into the sealer by hand, to make long seals or seal around odd shaped products. It makes 1" wide seals at speeds of up to 30 feet per minute. Available in flat seal (Model F), flat seal with teflon coating (Model F-T), or twin-grooved seal (Model G). CE approved 50/60 cycle, 220-240VAC, single-phase electrical is also available as an option on the PackRite Hand Rotary Sealers.

Model No.	Description	Price
Model F	Flat Seal	\$650.00
Model G	Twin Grooved Seal	\$650.00
Model F-T	Flat Seal with Teflon Coating	\$760.00
230VAC	230VAC Electrical	\$75.00

HEAT SEAL

MODEL S HAND IRON

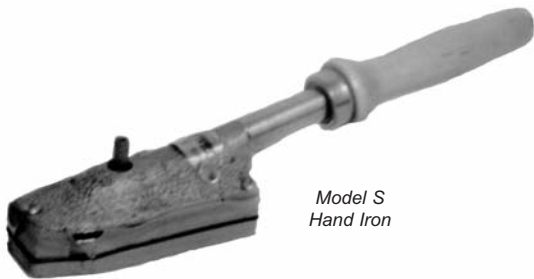

Model S
Hand Iron

The **Heat Seal Model S Hand Iron** is useful for a wide variety of applications including sealing plastic film and cigarette stamp application. Teflon covered for smooth, non-stick application of heat. The face of the iron is 1-3/4" x 4". Comes with adjustable thermostat and 6-foot power cord.

Model No.	Price
Model S Hand Iron	\$75.00
Replacement Parts:	
Heating element	\$14.70
Teflon Cover	\$5.00
Thermostat	\$26.00
Knob for Thermostat	\$3.50
Wire Retainer	\$9.00
Wood Handle	\$9.00

HEAT SEAL

PORTABLE HOT PLATES



TT912 Hot Plate

The **Kwik Portable Hot Plate** by Heat Seal Equipment is used for heat sealing film wraps. Perfect for sealing food, sandwiches, and other products that are film wrapped. Can be used on a table top or counter. They come in two models: TT69 (6" x 9", 500W heat element) and TT912 (9" x 12", 1000W heat element). Each unit has an adjustable thermostat temperature control with a range of 100-550F and a non-stick teflon cover.

Model No.	Size	Price
TT69	6" x 9"	\$143.00
TT912	9" x 12"	\$179.00





ACCU-SEAL PNEUMATIC TUBE SEALER

The improved **Accu-Seal Model 50 Plastic Tube Sealer** is the economical answer for sealing plastic or plastic lined tubes, and is ideal for use in medical, cosmetic or scientific laboratory environments. This unit makes sealing racks of plastic tubes easy. Fast and reliable, this machine seals one rack of tubes in the time it takes to prepare a second rack. A set of 2 custom made racks are included with each machine.

Features of the Model 50 Tube Sealer include: 20" seal length, 1/8" or 1/4" seal width, single-sided impulse sealing, adjustable heat & cool timers, electronic temperature control, 2 tube racks, full 2-year factory guarantee. Options include: additional pairs of tube racks, portable cart with industrial air compressor, ultra-quiet lab compressor.

Works on standard 110 VAC power, compressed air required. When you order, please send us a minimum of 20 tubes in order to build your custom racks.

SPECIFICATIONS:

- Seal Width: 1/8" or 1/4"
- Seal Length: 20"
- Requirements: Power: 120 Vac, 3 Amps, Air: 1.5 CFM @ 60 Psi
- Size: Length: 24", Width: 13", Height: 14"
- Approximate Weight: 39 lbs.



Accu-Seal Model 50-223 Tube Sealer

Model No.	Price
Model 50-223 Tube Sealer - 1/8" Seal	\$2,494.00
Model 50-233 Tube Sealer - 1/4" Seal	\$2,644.00
Additional Tube Rack Pair-Standard Size	\$225.00
Additional Tube Rack Pair-Custom Size	\$400.00
220 Volt Electrical	\$275.00
Ultra-Quiet Lab Compressor	\$2,095.00
FOB: San Marcos, CA	

HEAT SEAL

KWIK BAG LOADER



Kwik BL-1 Bag Loader

Kwik Bag Loaders by Heat Seal make loading your wicketed bags a simple two-step operation--drop the product down the chute into the bag and pull off the bag ready to seal.

The Kwik Bag Loader comes with standard chute and all aluminum and stainless steel construction. The Model BL-1 is adjustable to any position from flat to 90° vertical for ease in loading.

The constant air flow of 60 cubic feet per minute keeps the bag open while you load. Versatile, handles up to 6" wide wickets on a 12" wide bag table. Works on standard 110-120 volt electrical.

Model No.	Price
BL-1 Bag Loader with Standard Chute	\$459.00
FOB: Cleveland, OH	



TEFLON CLOTH & TEFLON TAPE

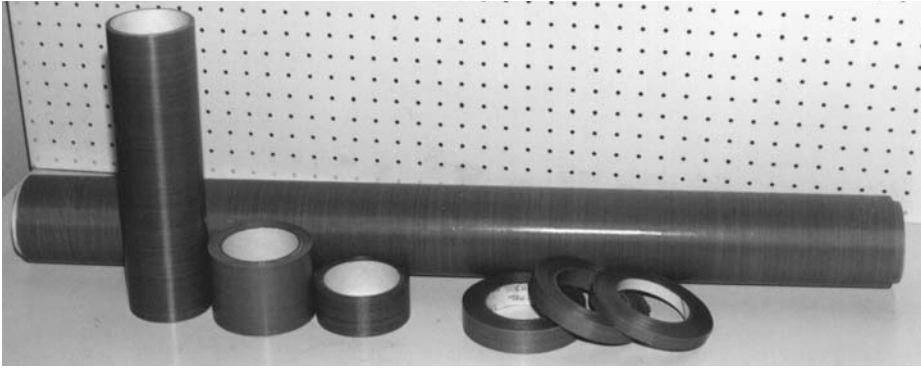

West Coast Plastics offers teflon impregnated fiberglass cloth and teflon impregnated fiberglass adhesive tape. For use in a wide variety of applications including sealers, packaging machines, heat platens and hot plates.

Teflon Impregnated Fiberglass Cloth 36-Yard Rolls

Width	3 mil	5 mil	6 mil	10 mil
1/2 in.	10.34	15.28	20.12	22.85
3/4 in.	15.51	22.93	30.19	34.28
1 in.	20.68	30.57	40.25	45.70
2 in.	41.37	61.13	80.50	91.40
3 in.	62.05	91.70	120.75	137.10
4 in.	82.73	122.27	161.00	182.80
6 in.	124.10	183.40	241.50	274.20
8 in.	165.47	244.53	322.00	365.60
10 in.	186.15	305.67	402.50	457.00
12 in.	248.20	366.80	483.00	548.40
Sq. Yard	27.00	38.00	54.00	65.00

Adhesive Teflon Impregnated Fiberglass Tape 36-Yard Rolls

Width	3 mil	5 mil	6 mil	10 mil
1/2 in.	25.44	31.71	34.33	39.52
3/4 in.	38.16	49.50	51.50	59.27
1 in.	50.88	63.42	68.67	79.03
1-1/2 in.	76.33	95.12	103.00	118.55
2 in.	101.77	126.83	137.33	158.06
3 in.	152.65	190.25	206.00	237.09
4 in.	203.53	253.67	274.67	316.09

*Other Sizes Available--
Call For Pricing.*

NICHROME, HIGH-TEMP WIRE & CONNECTORS

High Temperature Hook-Up Wire Nickel Clad Copper Conductor

Wire Size	Max Voltage	Temp. Rating	Price
18 ga. TGGT	600VAC	482°F	\$1.00/ft
16 ga. TGGT	600VAC	482°F	\$1.10/ft
14 ga. TGGT	600VAC	482°F	\$1.20/ft
12 ga. TGGT	600VAC	482°F	\$1.25/ft
10 ga. TGGT	600VAC	482°F	\$1.50/ft
8 ga. TGGT	600VAC	482°F	\$2.50/ft
14 ga. MGT-1000	600VAC	1000°F	\$1.70/ft
12 ga. MGT-1000	600VAC	1000°F	\$2.00/ft
10 ga. MGT-1000	600VAC	1000°F	\$3.00/ft

Nichrome Element Wire

.036 (19 gauge) Round (50-foot roll)	\$75.00/rl
1/8" x .004 Flat ribbon (50-foot roll)	\$67.50/rl
1/8" x .005 Flat ribbon (50-foot roll)	\$67.50/rl
3/16" x .004 Flat ribbon (50-foot roll)	\$67.50/rl
3/16" x .0063 Flat ribbon (50-foot roll)	\$67.50/rl
1/4" x .005 Flat ribbon - Hard Tempered (10-ft roll)	\$25.00/rl
1/4" x .005 Flat ribbon - Hard Tempered (15-ft roll)	\$37.50/rl
1/4" x .005 Flat ribbon - Hard Tempered (25-ft roll)	\$62.50/rl

Other Sizes Available! (100 ft. minimum order)



Wire Connectors

Solderless Insulated Terminals -40°F to +220°F

Code No.	Gauge	Stud Size	Type	Price
G31-947	22-18	10	Ring Terminal	\$8.00/25
G21-438	16-14	8-10	Ring Terminal	\$17.50/100
G21-440	12-10	8-10	Ring Terminal	\$22.50/100
G22-865	8	1/4"	Ring Terminal	\$22.50/50
G21-428	22-18	--	Butt Connector	\$17.50/100
G21-429	16-14	--	Butt Connector	\$17.50/100
G21-430	12-10	--	Butt Connector	\$22.50/100

High Temperature Non-Insulated Terminals to +900°F

G21-423	22-18	8-10	Ring Terminal	\$17.50/100
G21-425	16-14	8-10	Ring Terminal	\$17.50/100
G21-427	12-10	8-10	Ring Terminal	\$17.50/100
G21-442	8	1/4"	Ring Terminal	\$10.00/25
G21-411	16-14	--	Butt Connector	\$17.50/100
G21-412	12-10	--	Butt Connector	\$17.50/100

West Coast Plastics Equipment Inc., 623 S. Hindry Ave., Inglewood, CA 90301 (new address)

CALL TO ORDER 800-392-8569 / 310-215-3186 or FAX 310-642-0468 01/17

Web Page: www.wcpsealers.com E-Mail: sales@westcoastplastics.com



PRODUCT INDEX

- A -	
Accu-Seal	9,15,16,32,33,54
5300 Series Validatable Sealers	32
6300 Series Validatable Sealers	32
6400 Constant Heat Medical	33
675 Series Vacuum Sealers	15
8000 Series Medical Vacuum	33
Budget 235 Vacuum Sealers	15
HDMP-3 Pneumatic Impulse Sealers	9
HDMP-3 Pneumatic Gas-Vacuum Sealers	16
Stand, Machine	16
Tube Sealer, Model 50	54
Validatable Sealers	32-33
Audion	3,4,5,18,28,29,52
Band Sealers, 552 Horizontal	28
Band Sealers, 552MED Validatable	29
Futura Portable Hand Sealers	52
Magneta, Sealmaster	3
Parts	4
Pronto	4
Sealboy	4
Super Poly	5
Vacuum Chambers	18
Auto Sealers, TEW	9
Auto-Baggers, Clamco	28,34,35,36
Automatic L-Bar Sealer	42,47
- B -	
Bag Loaders	54
Bag-in-Box Vacuum Sealer	17
Bags, Vacuum	11
Baggers, Rollbag	28,34,35,36
Band Sealers	21-28,31
Bar Sealers, Economy	38
Bar Sealers, Harwil	5
Barrier Sealers, PAC	13,50,52
Budget Vacuum Sealer, Accu-Seal 235	15
- C -	
Cello Sealers	50,51,52
Chamber, Vacuum	19,20,21
Clamco	28,34,35,36,41-47,51
1075 Rollbag (demo unit)	28,34
R1275 Automatic Rollbag	34
R2300 Automatic Rollbag	35
575B Semi-Automatic Rollbag	36
Automatic L-Bar Sealer	42
Combo Shrink System	41,43,46
Semi-Automatic L-Bar Sealer	41,44
Side Sealer	47
Tunnel, Shrink	42,45
Vacumaster Skin Packager	51
Coffee Pac Vacuum Sealers, PAC	13,14,17
Compressors, Ultra Quiet	16,18,36
Constant Heat Sealers	5,50,51,52,53
Conveyors, Ingalls	36
- D -	
Damark Shrink Packaging Machines	39,40
Heat Tunnels	39
Maxi-Pak Shrink Pkg. Systems	40
Semi-Automatic L-Bar Sealers	39
- E -	
Economy TEW Sealers	1,2,9,27,38,50
Auto Sealer, Electromagnetic	9
Band Sealers	27
Constant Heat Hot Jaw Sealers	50
Foot Operated Sealers	2
Hand Operated Sealers	1
I-Bar Sealers	38
Imprinter, Hot Stamp	2
Long Bar Sealers	1
Emplex	21,22,23,24,25,26,31
ACS6200 Semi-Automatic Sealing System	25
Accessories, Band Sealers	26
Conveyorized Band Sealers	21,23,24,25,26,31
Heavy-Duty Band Sealers	21,24,25
InstaPack Automated System	25
MPS6000 Series	22,23,25,31
MPS7000 Series	21,24
Portable Band Sealer, MPS Lite	26
Semi-Automatic Sealing System, ACS Series	25
Table-Top Band Sealers	22,26,32
- F -	
Film, Shrink	38
Flow Wrappers	48
Food Wrappers, Heat Seal	49
Form, Fill & Seal-Horizontal	48
Fresh Pac Vacuum/Gas Sealer	17
FRM-1120C Band Sealer	27
Futura, Audion Portable Sealers	52
- G -	
Gramatech	6,8,12
Hand-Held Portable	6
Impulse Sealers, Pneumatic-GS	8
Mighty Mutt Vacuum Sealers-MPV	12
Vacuum Sealers-GVS	12
Gun, Milwaukee Heat	38
GVS Vacuum Sealers	12
- H -	
Hand Iron, Model S	53
Harvil Bar Sealers	5
Heat Gun, Milwaukee	38
Heat Seal Equipment	49,52,53,54
Bag Loaders	54
Constant Heat Hot Jaws	52
Food Wrappers, Table Top	49
Hand Iron, Model S	53
Hot Plates	53
Magic Wand Shrink Wrappers	49
Heat Shrink Tunnels	39,41,42,43,45,46
Hot Jaw Sealers	50,51,52
Hot Plates, Heat Seal	53
- I -	
Imprinters, Hot Stamp	2
Ingalls Conveyor Systems	36
InstaPack Automated Band Sealer	25
IP66 VacPack Vacuum Sealer	11
- J -	
- K -	
Kwik Bag Loaders	54
Kwik Constant Heat Hot Jaws	52
- L -	
L-Bar Sealers	39,40,41,42,43,45,46,47
Loaders, Bag	54
Long Bar Impulse Sealer, TEW	1
- M -	
Magic Wand Portable Shrink Wrap System	49
Medical Sealers	29-33
Mighty Mutt Vacuum Sealer	12
Model S Hand Iron	53
Motor Jaw Sealers	51
MPV-18 Vacuum Sealers, Gramatech	12
- N -	
- O -	
- P -	
P.A.C. Packaging Aids Corp.	3,4,5,10,13,14,17,18,28,29,30,48,50,52
AudionVac Vacuum Chambers	18
Band Sealers, 552 Horizontal	28
Band Sealers, 552MED Validatable	29
Band Sealers, Table-Top	30
Coffee Pac Vacuum Sealers	13,14,17
Flow Wrapper 350T & FW-400F	48
Fresh Pac Vacuum Sealers	17
Futura, Audion Portable Sealers	52
Magneta, Sealmaster	3
MedPac Validatable Sealers	30
Pac-Vac Vacuum Sealers	13,14
PB Pneumatic Barrier Sealers	50
PI Pneumatic Impulse Sealers	10
PT Table-Top Pneumatic Impulse Sealers	10
PT-Med Table-Top Validatable Sealers	30
PVB Vacuum Barrier Sealers	13,50
PVG Vacuum Impulse Sealers	13
PVT Table Top Vacuum Sealers	14
Pronto	4
Sealboy	4
Super Poly	5
Pac-Vac Vacuum Impulse Sealers	13,14
PackRite	51,53
Hand Rotary Sealers	53
Motor-Jaw Sealers	51
PackRite (cont.)	
Thermo-Jaw Sealers	51
Plexpack VacPack IP66 Vacuum Sealer	11
Poly Sealer, Audion Futura	52
Poly-Nylon Vacuum Bags	11
Polyolefin Shrink Film	38
Portable Band Sealers	26
Portable Hand Sealers	5,6,52,53
Promarks Vacuum Chambers	19
- Q -	
- R -	
Rollbag Machines	28,34-36
Rotary Sealers, PackRite Hand	53
- S -	
Scales, Weigh Right	37
Sealboy, Audion	3
Sealmaster, Magneta	3
Self-Contained Vacuum Sealer, Gramatech	12
Shrink Film	38
Shrink Packaging	38-47,49
Side Sealer, Clamco	47
Sipromac Vacuum Chambers	20
Skin Packager, Vacumaster	51
- T -	
Teflon Cloth & Tape	55
TEW	1,2,9,27,38,50
Band Sealer FRM-1120C	27
Band Sealer, Table Top HL-810e	27
Constant Heat Sealers	50
Film Rollers	1
Hot Stamp Imprinters	2
I-Bar Shrink Sealer	38
Long Bar Sealers	1
TISA- Auto Sealers	9
TISF- Foot Pedal Sealers	2
TISH- Hand Sealers	1
Tube Sealers	54
Tunnels, Heat Shrink	39,41,42,43,45,46
- U -	
Used Rollbag Machine	28
- V -	
VacPack IP66 Vacuum Sealer	11
Vacumaster, Skin Packager	51
Vacuum Bags, Poly-Nylon	11
Vacuum Band Sealer, Emplex	21
Validation, Medical	32
Validatable Sealers	29-33
Vertrod	6,7,8
Hand-Held Portable	6
Open-Back Pneumatic Sealers	8
Steel-Frame Heavy-Duty Sealers	7
- W -	
Weigh & Fill Machines, Weigh Right	37
Weigh Right Scales	37
Wire	55
Connectors	55
High Temp	55
Nichrome	55
Wrappers, Flow	48
Wrappers, Food	49
- X - Y - Z -	

FEATURED INSIDE:



Manual Impulse Sealers p.1-6



Portable Sealers p.5,6,52



Pneumatic & Motorized Impulse Sealers p.6-10



Vacuum Sealers p.11-21,50



Vacuum Chambers p.18-20



Band Sealers p.21-29,31



Medical Packaging p.29-33



Baggers & Wrappers p.28,34-37,48



Shrink Packaging p.38-47,49



Constant Heat Sealers p.5,50-53



Tube & Other Sealers 51,53-54



Materials 11,38,55

*** Also, check out our "Bargain Box" online ***

Web Page: WCPSEALERS.COM

E-Mail: sales@westcoastplastics.com

NEW Address: 623 S. Hindry Ave., Inglewood, CA 90301

Main Phone: 800-392-8569 or 310-215-3186, Arizona: 480-443-9669

Main Fax: 310-642-0468, Arizona Fax: 480-991-2484

We Moved!!