

Quick Ship

• Same or next day shipment on all stock units.

Ceramic Fiber Products

Ceramic Fiber Heaters

The ceramic fiber heater product line offers some of the highest temperature heating element capabilities in the Watlow family of heaters. Ceramic fiber heaters are made by integrating an iron-chrome-aluminum (ICA) heating element and ceramic fiber insulation for a new concept in application problem solving...**"heated insulation!"**

Heating units constructed of ceramic fiber insulation isolate the heating chamber from the outside. Ceramic fiber heaters are extremely low mass, high insulation value units with self-supported heating elements. Many applications can benefit from the convenience of the heating element and insulation combined into one package.

Ceramic fiber is an insulation made of an alumina-silica composition, held together by an inorganic binder. It's commonly used as a refractory material. Its lightweight, low-density properties make it ideally suited for high temperature applications requiring low thermal mass.

Performance Capabilities

- Operating temperatures up to 2200°F (1204°C) (See [page 143](#) for detailed limits.)
- Watt densities from 5 to 30 W/in² (0.8 to 4.6 W/cm²)
- Uses "radiant" heat transfer exclusively

Features and Benefits

- **High temperature iron-chrome-aluminum (ICA) resistance elements** are integrally bound into position. Five element configurations are available for many applications.
- **Lightweight, low-density alumina-silica composition** is molded to shape, acting as insulation to isolate the heating chamber from the outside. This low shrinkage fiber and inorganic

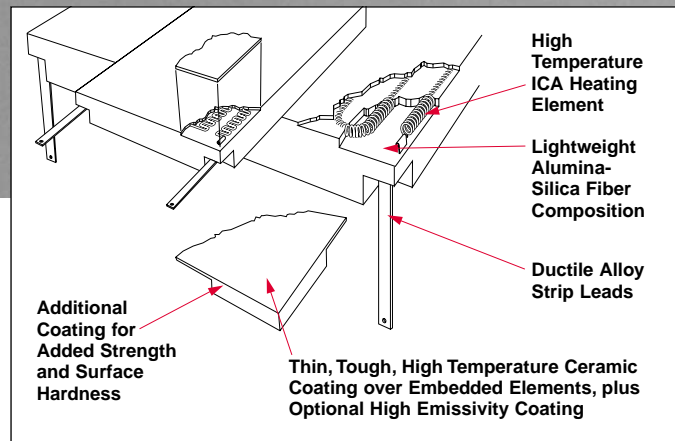
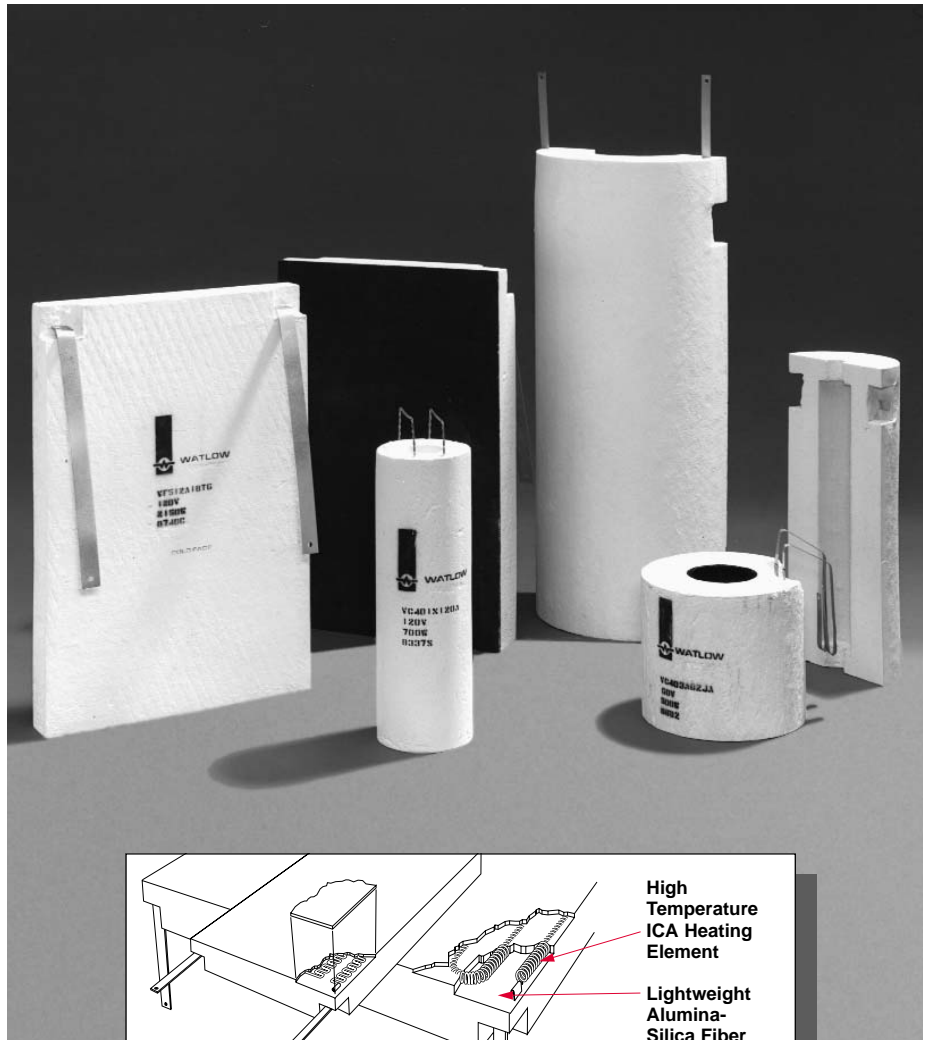

binder assures a firm, thermal shock resistant, self-supporting unit at all operating temperatures.

- **Operating temperatures up to 2200°F (1204°C)** provide high temperature performance not possible with many other heater types. (See [page 143](#) for detailed limits.)
- **Low mass ceramic fiber insulation of 10 to 15 lb/ft³ (160 to 240 kg/m³)** allows the heater to

reach process temperature quickly and allows the energy to heat the load instead of wasting energy on itself.

- **Works directly off common power line voltages**, eliminating the need for expensive transformers or complex power control systems. Compatible with the full range of Watlow temperature controls and power switching devices.

Ceramic Fiber Products

Ceramic Fiber Heaters

Applications

- High temperature furnaces
- Metal melting, holding and transfer
- Semiconductor processing
- Glass, ceramic and wire processing
- Analytical instrumentation
- Fluidized beds
- Laboratory and R&D
- Other high temperature process applications

Embedded Coil Elements

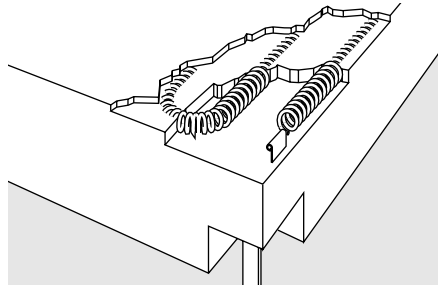

- Optimum performance for high temperature, enclosed furnace chambers.

- Coiled elements readily conform to complex curved surfaces, especially small custom chamber shapes.
- Coiled element design works best in higher voltage, lower current situations.
- Use where lower watt density requirements and low duty cycle operations are expected.
- Available in stock and standard units of medium watt density, rated up to 2000°F (1093°C). When ordering, refer to charts on **pages 154 to 157**.

Embedded Sinuated Elements

- Available in either flat or V-sinuated element configurations.
- Advanced V-sinuated element configuration allows up to 27 percent additional watt density over that of embedded flat sinuated elements.
- Performs best at medium to high temperatures at medium watt density power requirements.
- Use in partially enclosed to fully enclosed applications.
- Especially well suited for large, flat units; semi-cylindrical units

above five inches (125 mm) I.D.; and full cylinders above four inches (100 mm) I.D.

- Offers greater effective insulation thickness than coiled element designs.
- Enhances “heated insulation” concept of operational use.
- Features high emissivity coating on new high watt density series units. When ordering, refer to charts on **pages 158 to 160**.

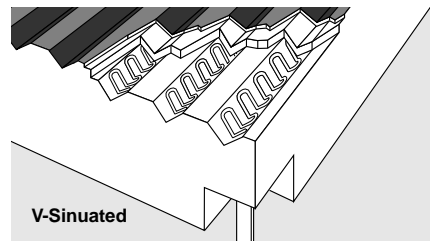
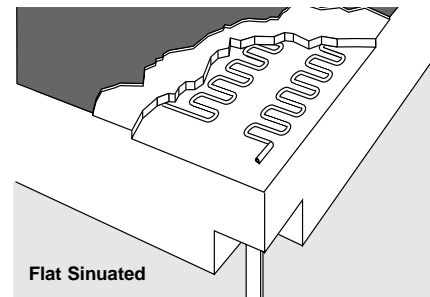

Exposed Sinuated Elements

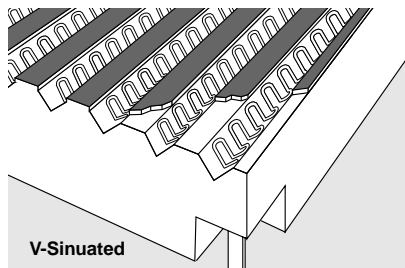
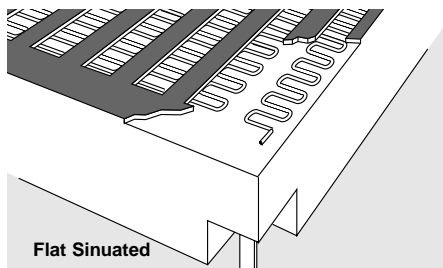

- Available in either flat or V-sinuated element configurations.
- Advanced V-sinuated element configuration allows up to 20 percent additional watt density over that of exposed flat sinuated elements.

- Offers the lowest possible wire-to-chamber temperature difference for maximum heater life.
- Provides the optimum heat-up/cool-down and recovery times as well as maximum efficiency of operation.

- Makes possible higher current handling capabilities.
- Minimizes the number of circuits and connections in large furnaces.
- Especially well suited for large, flat surface area units and large I.D. curved unit.
- Exposed elements are available on special order as a variation of the embedded sinuated element normally provided on stock and standard units. When ordering, refer to charts on **pages 158 to 160**.

Ceramic Fiber Products

Ceramic Fiber Heaters

Applications and Performance Data

Performance Capabilities

The following *Performance Envelopes* graph represents the capabilities of the five heater element configurations previously mentioned. The curves compare upper temperature limits versus permissible design watt densities to achieve a **standard heater life expectation of 2,000 hours**.

As with all Watlow heaters, the major application concern deals with the heater's surface watt density as it relates to the application temperature, such as the furnace chamber temperature or the radiant surface temperature. When evaluating an application for temperature and watt density requirements, it should fall to the left

of, and below, the performance limit lines. If the application falls into this area, then it's in the **safe performance area**. The further into this safe performance area, the greater will be the life expectations of that heater. If an application requires temperatures or watt densities that fall into the area to the right of, and above, the lines, then the application is **beyond** the heater's typical design or performance limits. Using a heater required to perform in this area of the graph may result in shorter life expectancy. For information specific to an application, contact a Watlow sales engineer or authorized distributor.

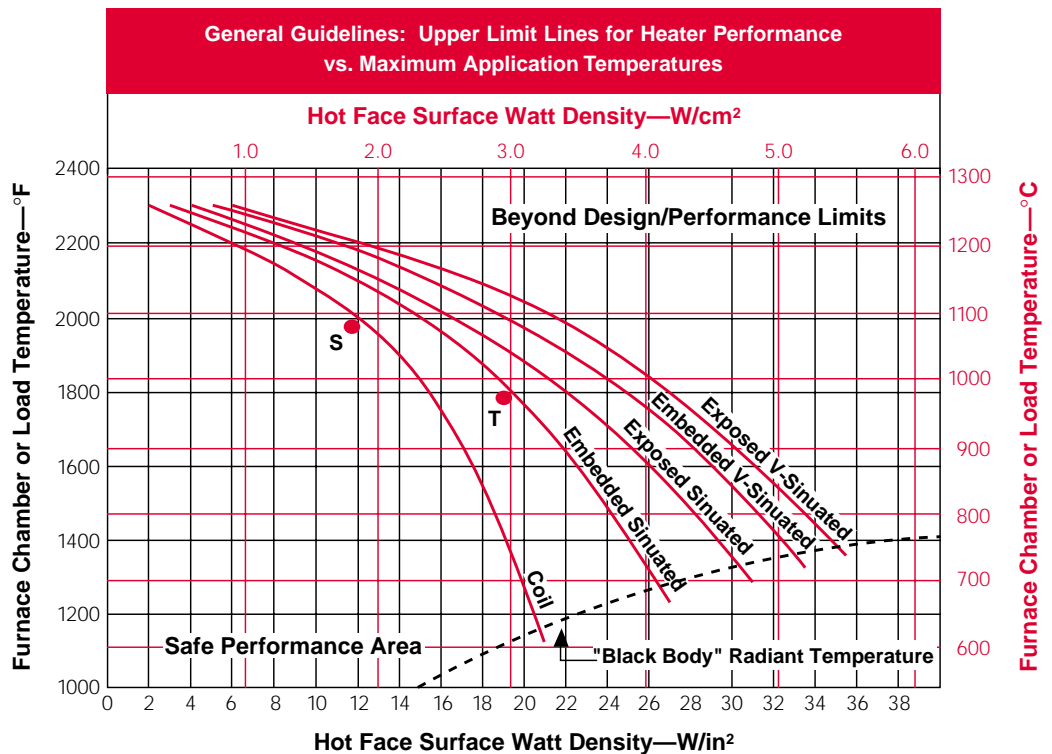

Ceramic Fiber Products

Ceramic Fiber Heaters

Applications and Performance Data

Continued

The following graphs provide technical data to help evaluate the performance and select the correct ceramic fiber heater for an application.

These four graphs represent performance data for heat-up/cool-down rates and power requirements to maintain furnace temperature. This data is the average of test results performed for two of the most typical types of furnace chambers, and should not be used for specification purposes.

Small, Full Cylinder, Heated Chambers

Test conditions for small, full cylinder heated chambers are typical of analytical instrumentation furnaces. Several stock sizes are represented. The units tested were six inches (150 mm) long, mounted in a vertical orientation. Both ends

were capped with one inch (25 mm) of ceramic fiber insulation. No additional insulation or metal sheath was added to the outside diameter. The temperature was measured by a thermocouple located in the geometric center of the chamber.

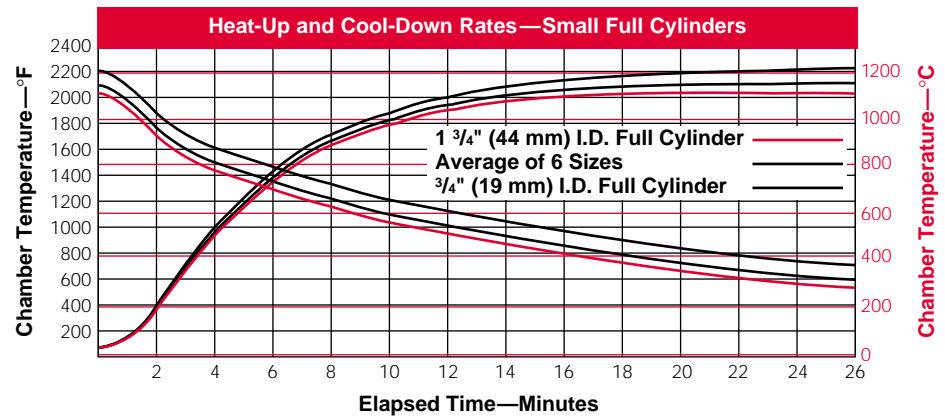

Power Requirements

Below are the percentages of rated power needed to achieve and hold specific temperatures inside the full cylinder chambers tested.

Thus this represents the efficiency of these heaters in this mounting configuration.

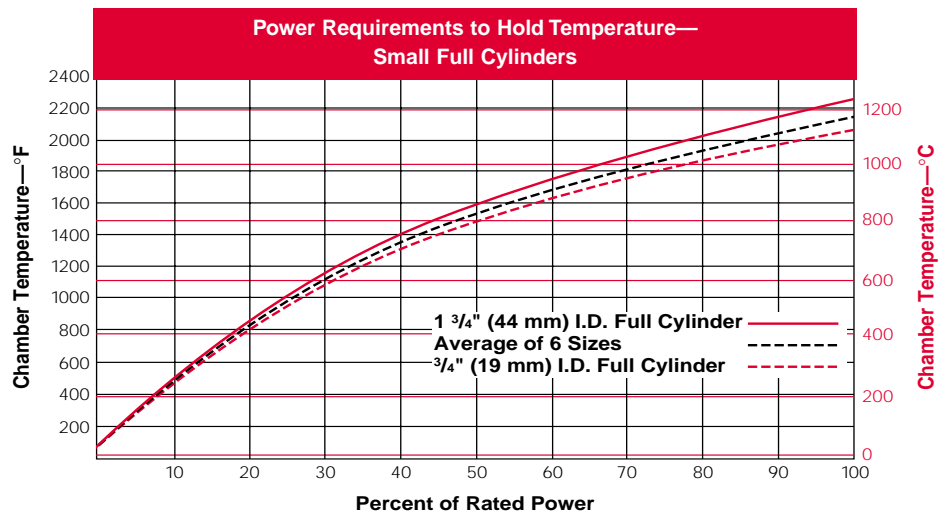

Ceramic Fiber Products

Ceramic Fiber Heaters

Applications and Performance Data

Continued

Medium Sized, Insulated Closed Chambers

Test conditions for medium sized, insulated chambers are typical of pit and box furnaces, large tube furnaces and pipe and reactor heating. Standard embedded coil units (Watlow code number VS412A12S) were used, rated for 2000°F (1093°C). The test chamber size was 12 inches long and 12 inches I.D. (305 X 305 mm). The volume was approximately 0.75 ft³ (0.02 m³).

Temperature heat-up rates were measured by thermocouples in three places: at the element, on the heater surface and at the center-of-chamber. Data for various additional wall thicknesses is also shown. This is typical of how large flat and semi-cylindrical units would be used. The chamber was oriented vertically with top and bottom disks of ceramic fiber insulation equal to wall thickness.

Ceramic Fiber Products

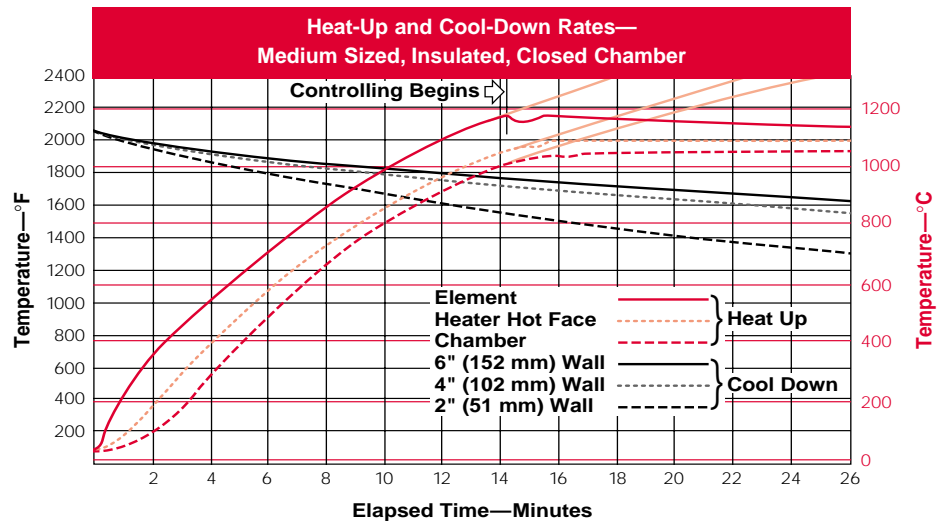

Power Requirements

Below are the percentages of rated power needed to achieve and hold specific temperatures inside

medium sized, insulated chambers. Thus this represents the efficiency of these heaters in this mounting configuration.

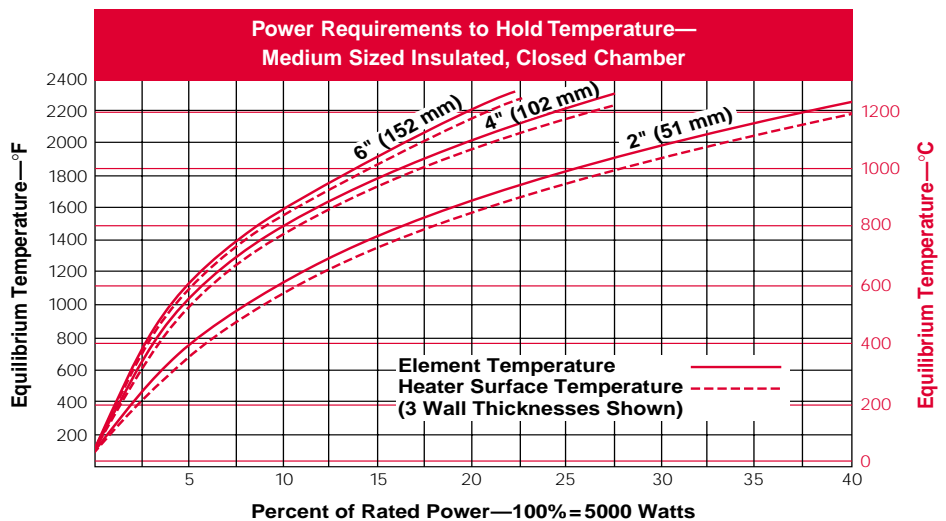

Ceramic Fiber Products

Ceramic Fiber Heaters

Applications and Performance Data

Continued

Insulation Effectiveness

The graphs below demonstrate the effectiveness of adding 6 lb/ft³ (96 kg/m³) blanket insulation to the backside of standard two inch (50 mm) thick ceramic fiber heaters.

Total wall thickness of up to six inches (152 mm) is shown. Data is for vertical sides, without metal sheathing. Top and bottom surfaces, and surfaces with metal sheaths over the ceramic fiber insulation will be different.

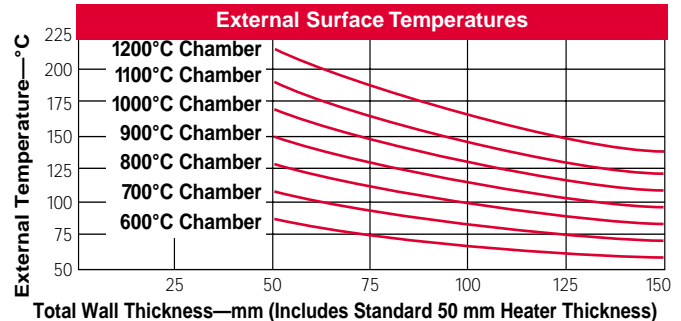
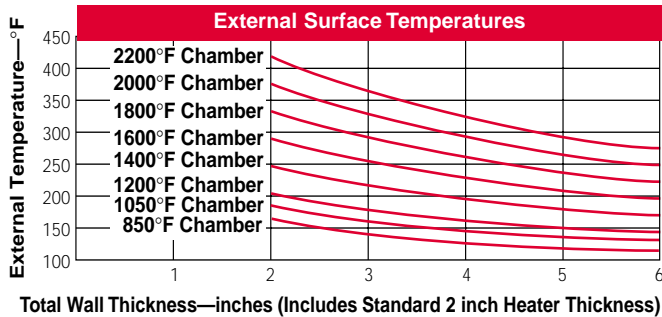

Heat Loss and Energy Transfer

For general calculations of heat loss and energy transfer, the *Insulation K-Factors* and *Emissivity* graphs are helpful.

The *K-Factors* graph is for ceramic fiber heaters and the ceramic fiber insulation blanket, which is typically used with the heaters. This blanket is offered as an accessory by Watlow.



Application Hints

For wall thicknesses (T) in cylindrical situations use the "equivalent thickness" conversion.

$$T_{cyl.} = r_{out} \log_e \left(\frac{r_{out}}{r_{in}} \right)$$

Where r_{out} is outer radius
 r_{in} is inner radius

Emissivity of Heater Surface

The emissivity graph details the normalized emittance values for the four surfaces most likely to be encountered when planning Watlow ceramic fiber heater applications.

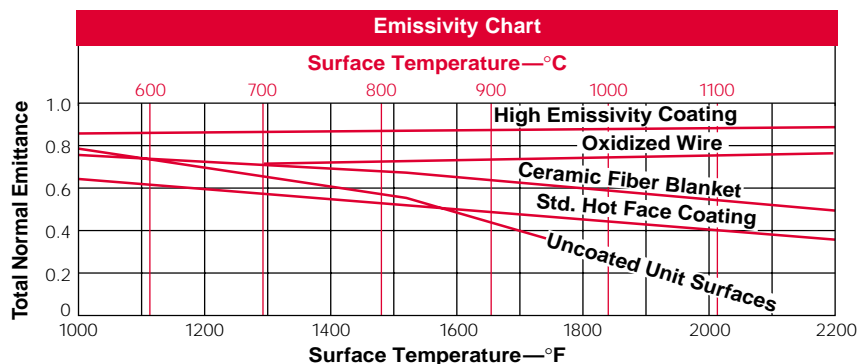
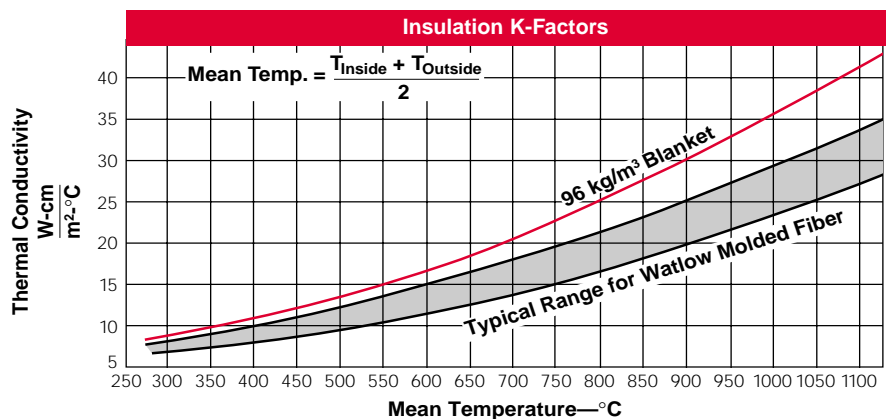
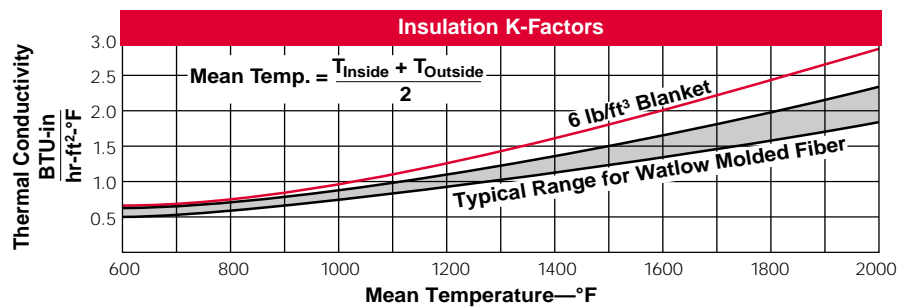

Ceramic Fiber Products

Ceramic Fiber Heaters

Mounting Methods



Warning

This product contains refractory ceramic fibers (RCF) which have been identified by the International Agency for Research on Cancer (IARC) as a possible human carcinogen (class 2B).

Before using the products, read the MSDS which contains the detailed precautionary measures and handling instructions.

The Watlow ceramic fiber heater product line presents a wide range of heater shapes and configurations for solving high temperature process applications. The modularity and range of sizes and wattages provides the greatest possible flexibility when using these heaters. At the same time, this requires many different mounting solutions. Watlow has developed or can recommend

many appropriate specific and generalized mounting systems for solving your mounting problem. Watlow has arranged the ceramic fiber heaters into seven major mounting categories or heater system configurations, shown in the following illustrations. The MODULE-MOUNT® system, due to its importance, is treated in the most detail on the following pages.

1. Full Cylinder Heaters



2. Semi-Cylindrical (180 degree section) Heaters

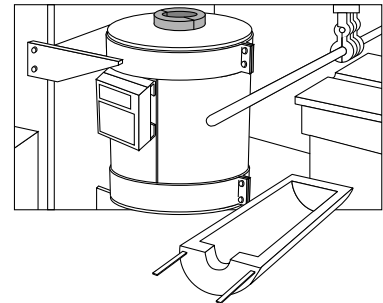

3. Arc-Section Arrays of Heaters (3 or more units of 120 degree or less each)

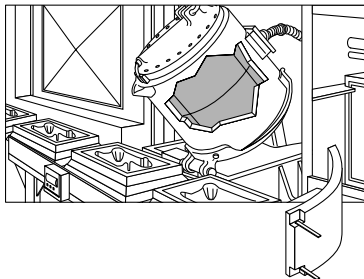

4. Flat Panels, with One Panel on Each Side

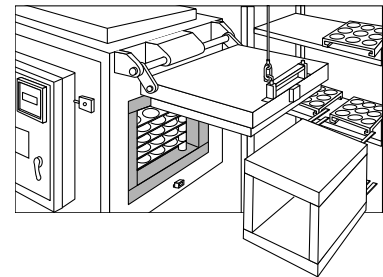

5. Flat Wall Array with Minimum Two-by-Two Units per Wall

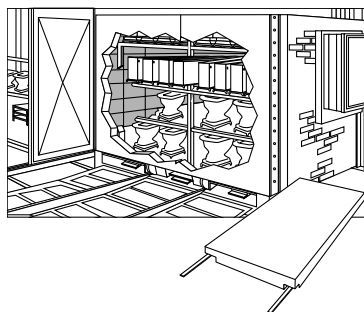

6. Made-to-Order Molded Shapes with up to Five Sides of a Box Molded as One Piece, Including Complex Curves

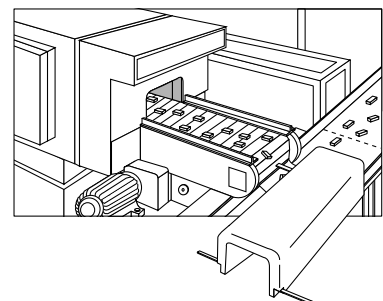

Ceramic Fiber Products

Ceramic Fiber Heaters

Mounting Methods

Continued

7. MODULE-MOUNT System

The Watlow MODULE-MOUNT system is more than a mounting method. It's a design solution that integrates ceramic fiber heaters with a shell for mounting on an optional steel "space-frame" structure.

Combining the heaters and mounting assembly in one unique package provides ease of installation—and makes the heater more accessible for maintenance—minimizing downtime.



Performance Capabilities

- Holds ceramic fiber heaters capable of operating up to 2200°F (1205°C)
- Watt densities up to 25 W/in² (4 W/cm²)

Features and Benefits

- **"Hot change" feature** allows individual heater replacement without total system shutdown or disassembly.
- **"Spaceframe" structure** can be designed to hold from four to more than 18 heaters. Also accommodates heater sizes from as small as four to 12 inches (102-305 mm) wide and up to 48 inches (1220 mm) tall.
- **Design flexibility** is ideal for **flat and curved** wall heaters. The Spaceframe could be customized to hold any heaters that conform with size, shape and electrical rating limitations.
- **Operates off power line sources** from 120 to 600V~(ac), single or three phase. NEMA1 terminal boxes are provided as standard.

System Designs

The MODULE-MOUNT system examples presented here are for crucible and retort furnaces. Also represented here are floor and leg mounted configurations. Together this represents an overview of how the MODULE-MOUNT system can be used in several typical applications, such as aluminum crucible furnaces, retorts, vacuum tanks, fluidized beds, lead pots and more. The cross-sectional illustration is to help visualize the MODULE-MOUNT system concept.

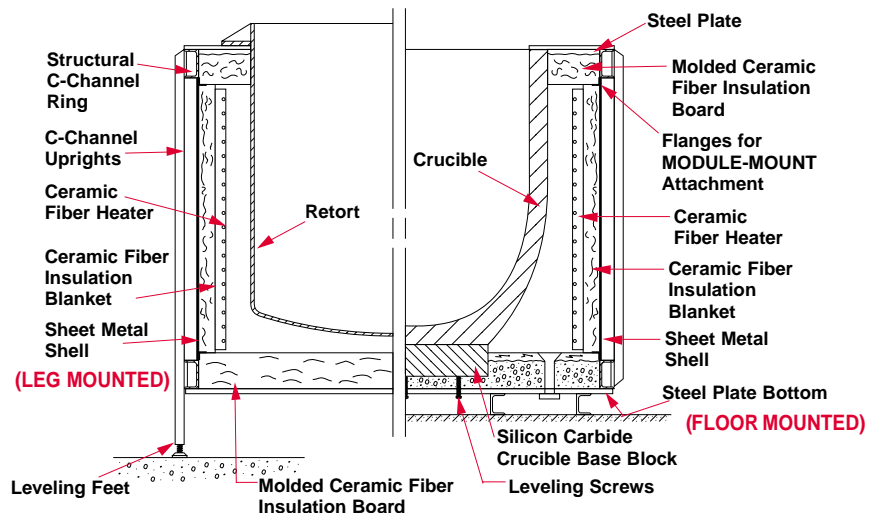

Ceramic Fiber Products

Ceramic Fiber Heaters

Mounting Methods

Continued

MODULE-MOUNT System

Construction Details

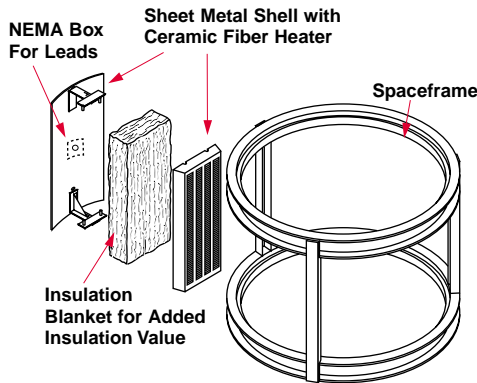

Flat and arc-section panels, used in one-by-multiple unit arrays. This is the MODULE-MOUNT system.

The MODULE-MOUNT system consists of four basic components: the ceramic fiber heater, additional insulation blanket and a sheet metal shell to hold the heater and insulation blanket. The Spaceframe would be made by the furnace builder to meet custom application design.

The back side of the ceramic fiber heater is slotted to accept cemented-in tubes for connecting the heater to the shell. The reusable shell can be made of the most appropriate sheet metal (aluminized steel is used as the standard) to meet operating environment conditions. Several layers of reusable ceramic fiber blanket are placed between the shell and heater, adding insulation value [typically the heater is two inches (51 mm) thick, with three inches (76 mm) of blanket].

Sizes and Specifications of Representative MODULE-MOUNT System Designs

The specification chart is to help understand the range of systems possible. Basic considerations include: total size, load to be heated, heater configuration and power requirements. The MODULE-MOUNT system is very flexible in terms of both range of sizes and the types of loads that can be heated. Since the number of heaters around an object could range from four to any number, MODULE-MOUNT heaters can be assembled to meet virtually any application. Typically, MODULE-MOUNT assemblies are divisible by three to accommodate three-phase power and, if necessary for vertical

zoning, can be arranged in stacked vertical rings. The MODULE-MOUNT system concept can be applied to virtually any size object for which a suitable Spaceframe can be constructed. Since almost any size object can be accommodated, there are no available standard or stock sizes in the MODULE-MOUNT system. Instead, stock and standard ceramic fiber heaters are available to adapt for use in a MODULE-MOUNT system. Watlow can also provide made-to-order ceramic fiber heaters to meet exact application requirements.

Ceramic Fiber Products

Typical MODULE-MOUNT System Designs

The chart below lists the different specifications for typical applications of the MODULE-MOUNT heating system.

Load Type	Lead Pot	Fluidized Bed	Retort	Aluminum Crucible*	Aluminum Crucible*
Load Weight lbs (kg)	1000 (455)	400 (180)	1100 (500)	620 (280)	2400 (1090)
Load Size Top O.D. in (mm)	14 (355)	22 (560)	28 (710)	28.25 (715)	40 (1015)
Load Size Height in (mm)	20 (510)	28 (710)	48 (1220)	22.75 (580)	27.5 (700)
Total System Power kW	16.0	38.7	60.0	46.8	84.0
Number of Heaters	6	9	9	12	12
Heater Array I.D. in (mm)	17 (430)	28 (710)	34 (865)	34 (865)	48 (1220)
Chamber Height in (mm)	20 (510)	26 (660)	46 (1170)	26 (660)	30 (760)
Heater Size Width in (mm)	9.75 (250)	10 (255)	12.5 (315)	8.9 (225)	12.6 (320)
Heater Size Height in (mm)	18 (455)	24 (610)	44 (1115)	23 (585)	27 (685)
Heater Rating Volts	139	240	277	139	277
Heater Rating Watts	2667	4300	6675	3900	7000

* Watlow also offers from stock non-MODULE-MOUNT flat situated element replacement heaters for aluminum crucible furnaces used in the non-ferrous foundry and die-casting market.

Ceramic Fiber Products

Ceramic Fiber Heaters

Termination Options

Watlow has many variations of electric leads to meet particular wiring requirements. To understand the termination options available, it's necessary to understand the different ways electrical leads can be applied.

Ceramic fiber heater electrical leads are welded to stubs – the metal parts that interface between the heating element wire and the add-on electrical leads. These stubs exit the heater at the lead pockets. Pockets are small cavities, below the cold face plane (outside surface) and generally located at or near the corners.

Watlow ceramic fiber heaters come with either strip leads or double twisted wire leads. Strip leads are the most commonly used, unless otherwise specified. The various lead styles refer to the lead's exit orientation, relative to the pocket used on a given type of heater. See illustrations for specific details.



Important

Inspect the carton and its contents for damage prior to discarding packaging material. If there is any damage, contact a Watlow Representative immediately for a Returned Material Authorization (RMA) number. All damaged goods are to be returned in the original packaging to reduce the possibility of further damage to the product.

Strip Leads

Flat and semi-cylindrical ceramic fiber heaters are available with the termination options shown here. When ordering termination options for stock units, the specific strip lead **Style** must be specified. To determine the desired style, refer to the following illustrations. Otherwise, **Style A** leads will be provided and the length will be 12 inches (305 mm). Additional lengths are possible using add-on

leads which are priced per pair, per inch, for the three different widths. See ordering charts for which lead width is used on a specific heater. Strip leads are shipped with a $\frac{1}{8}$ inch (5 mm) hole at the end of the lead. Use #10-24 screws, nuts and washers, or other wiring connections. Caution should be exercised when making connections. Leads are susceptible to loosening due to thermal expansion and contraction as the heater cycles.

Flat Units

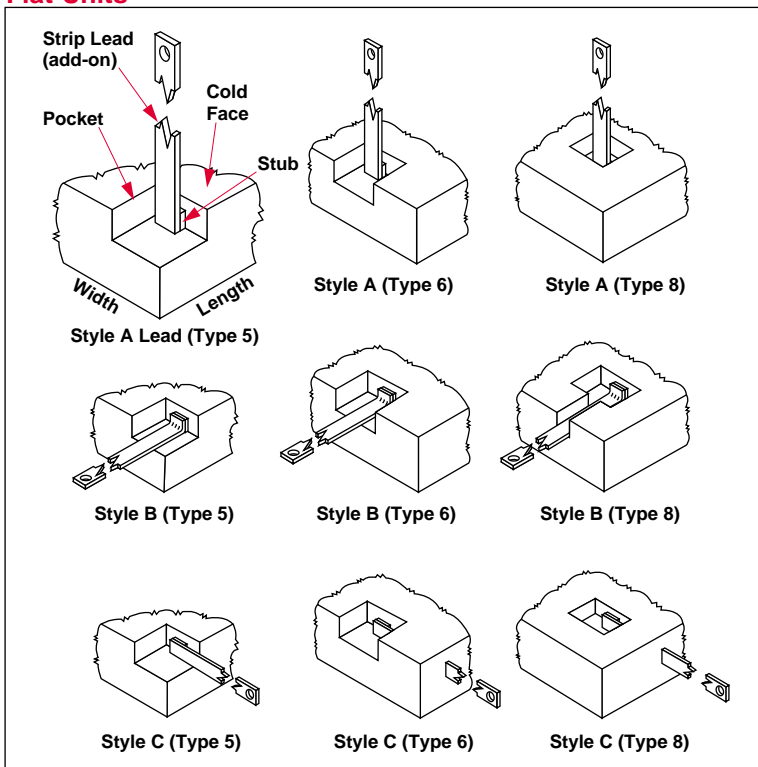

Semi-cylindrical Units

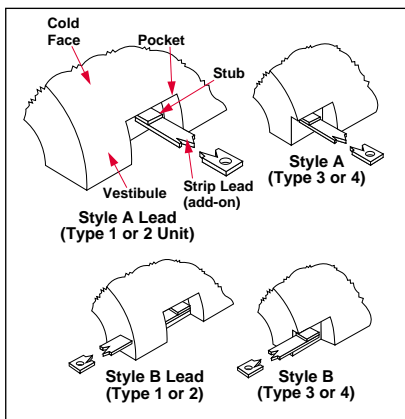

Ceramic Fiber Products

Ceramic Fiber Heaters Termination Options

Continued

Special Lead Orientation

If the various standard strip lead orientations and pocket configurations are not suitable, special designs are possible. When ordering, please include drawings that show proposed locations.

Leads Bent 90 Degrees

The double twisted leads of full cylinder heaters can be bent 90 degrees to lay into slots and exit to the sides of the unit.

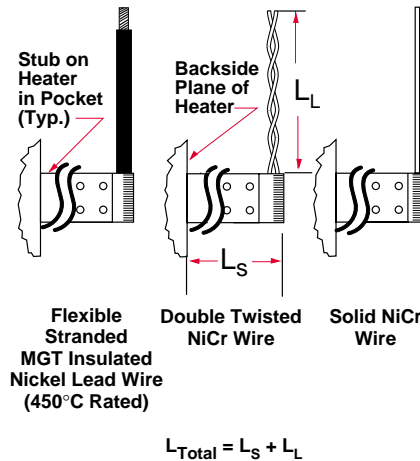

Special Add-On Lead Configurations

The three termination options illustrated can be welded onto the stub at the heater pocket, or better, welded on at the end of a specified length of the regular strip lead. L_S is the *Strip* lead length, which can vary from zero to the value necessary to get away from the hot zone. L_L is the length of the add-on lead. This additional add-on lead option makes it possible to use stock/standard units to satisfy a greater range of wiring requirements. Consult a Watlow sales engineer or authorized distributor for technical details and price.

Accessories

Ceramic fiber heater orders can also include the following accessory items, as detailed on this and following pages. Please specify the Watlow code number when ordering.

Rigidizer

Rigidizer is primarily used to recoat soft, cut edges of ceramic fiber heaters and ceramic fiber insulation panels. Various degrees of hardening can be achieved with additional applications. Rigidizer can be ordered by the pint (0.47 L) by specifying code number **CFRGD (PT)** or gallon (3.78 L), code number **CFRGD (GAL)**.

Powdered Ceramic Fiber

Powdered ceramic fiber is used primarily to improve surface finish in critical areas. It can also be used to repair damaged units by filling voids, cracks and broken corners. Use powdered ceramic fiber with rigidizer to make an easily applied paste. Standard container is one pint (0.47 L). Order code number **CFPDRF (PT)**.

Ceramic Tubes

Ceramic tubes are available in four nominal sizes: 1/8, 1/4, 3/8 and 1/2 inch I.D. and lengths of 0.9 inch (22 mm) and 1.9 inch (48 mm) long. Ceramic tubes have several uses, including thermocouple mounting holes, mounting pin sleeves and lead coverings. The table to the right lists code numbers and exact sizes.

B.T.E. Closed-End Thermocouple Tubes

Also available is a horizontal thermocouple tube between the elements. Two sizes are available: 0.140 inch (3.6 mm) and 0.265 inch (6.7 mm), both six inches long (152 mm) with closed end.

Ceramic Tubes

Inside Diameter in (mm)	Length in (mm)	Code No.
0.140 (3.6)	0.9 (22)	CC405-1
0.265 (6.7)	0.9 (22)	CC405-2
0.390 (9.9)	0.74 (19)	CC405-3
0.515 (13.1)	0.9 (22)	CC405-9
0.140 (3.6)	1.9 (48)	CC405-4
0.265 (6.7)	1.9 (48)	CC405-5
0.390 (9.9)	1.6 (41)	CC405-6
0.515 (13.1)	1.9 (48)	CC405-8

Dry Heating Surface Mix

Dry heating surface mix, which is used to make the hot face of all standard heaters, including those with the high emissivity coating, can also be used with rigidizer to make a very high temperature paste for touch ups of the hot face area. Order by the pint (0.47 L), code number **CFHTGSURMX**, or gallon (3.78 L), code number **CFHTGMX-GAL**.

High Temperature Coating and Electrical Potting Cement

Two different high purity, high temperature cements have multiple uses: mount thermocouple tubes, provide extra surface hardening, bond ceramic fiber gaskets and affix lightweight ceramic fiber insulation blanket to panels, as well as attach edge-spacer blocks and custom vestibules. Potting cement comes in a 1/4 pint (116 ml) jar, and may be ordered by specifying code number **CFPTGCMT**. The high temperature coating cement is available in pints or gallons, and can be ordered by the code numbers **CFCTGCMT (PT)**, **CFCTGCMT (GAL)**.

Ceramic Fiber Products

Ceramic Fiber Heaters Accessories

Continued

Ceramic Fiber Insulation Blanket

Additional insulation value for ceramic fiber heaters is available with ceramic fiber insulation blanket. This 6 lb/ft³ (96 kg/m³) ceramic fiber blanket

contains no organic binders. Suitable for applications up to 2300°F (1260°C). Sold in full rolls or cut by the square foot, these blankets are available in the following sizes:

Size (U.S.)	Size (metric)	Code No.
24 in x 25 ft x ¼ in	610 mm x 7.6 m x 6 mm	CFBLKT1/4*
24 in x 25 ft x ½ in	610 mm x 7.6 m x 13 mm	CFBLKT1/2*
24 in x 25 ft x 1 in	610 mm x 7.6 m x 25 mm	CFBLKT-1*

* Add ...R to end of Code No. for full roll.

Strip Lead Porcelain Bushings

Strip lead porcelain bushings are primarily used to protect heater power leads when passing through the metal walls and furnace structures. Bushings are available with inside diameters, listed below, for use with double

twisted leads and the three standard strip lead widths. To select the appropriate inside diameter lead bushing, see the heater selection tables on **pages 154 through 160**. The strip lead width for each heater is listed therein.

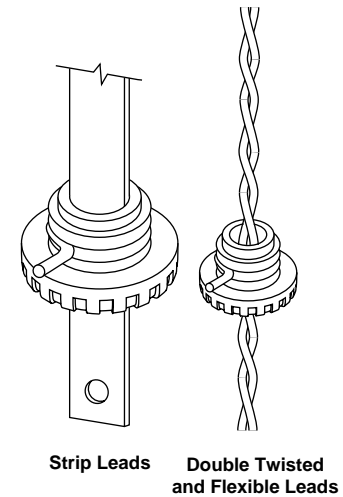
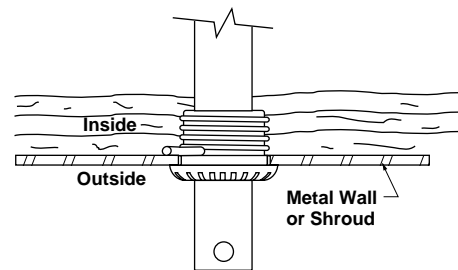
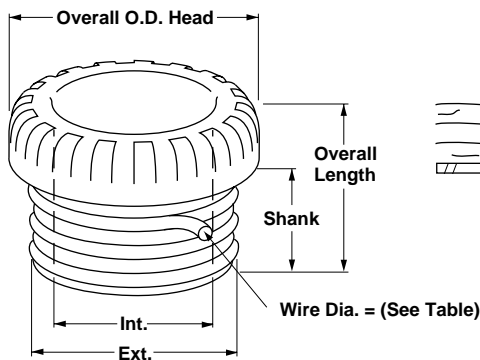

Porcelain Bushings Specifications

Conduit K.O. Size in (mm)	Shank Dia. without Wire Nut		Wire Nut Dia. in (mm)	Shank Length in (mm)	Overall Length in (mm)	Overall Head O.D. (Ref.) in (mm)	Use With:	Code No.
	Int. in (mm)	Ext. in (mm)						
⅜ (10)	⅜ (10)	21/32 (17)	0.080 (2.032)	⅜ (14)	⅜ (22)	⅜ (22)	All double twist	CS45-11
½ (13)	7/16 (11)	13/16 (21)	0.080 (2.032)	¾ (19)	1 1/8 (29)	1 1/8 (29)	⅜ (10 mm) Strip	CS45-20
¾ (19)	⅞ (14)	1 (25)	0.106 (2.692)	⅞ (22)	1 5/16 (33)	1 5/16 (33)	½ (13 mm) Strip	CS45-30
1 (25)	⅞ (22)	1 1/16 (33)	0.095 (2.413)	⅞ (22)	1 ¼ (32)	1 5/16 (40)	¾ (19 mm) Strip	CS45-42

Ceramic Fiber Products

Ceramic Fiber Heaters

Application Hints



- Never use ceramic fiber heaters for conduction heating applications. These heaters are designed for **radiant heat transfer only**.
- Use appropriate mounting methods such as pins, washers, clamping straps, overlapping edge clamps, interlocking edges, etc. Generally, these methods are better than cementing ceramic fiber heaters, because cementing will not accommodate the expansion and contraction caused by thermal cycling of the surrounding metal structures.
- Keep furnace loads free of oils, lubricants and other contaminants that can vaporize at high temperatures. Ceramic fiber heaters have a porosity exceeding 90 percent, and cannot be sealed against contamination infiltration and possible damage to the heating element wire.
- Use low mass thermocouples that are responsive to rapidly changing

radiant energy transfer conditions. Without proper temperature control, ceramic fiber heaters can generate sufficient heat for self destruction.

- Mount thermocouple junction directly above an element and within $\frac{1}{16}$ inch (1.6 mm) of the heated surface. Embedded ceramic mounting tubes are available as an option to position 0.125 inch (3.2 mm) diameter thermocouples inside the fiber, directly behind and between the elements. Heater wire operating temperatures are the critical factor, and should be monitored at the hottest point within the application.
- Electrical connections made in heated portions of the application must be rated for the appropriate currents and anticipated ambient temperatures. To ensure good electrical connections, use compression-type connection devices located as far away from the hottest area of the application. This minimizes the possibility of electrical connection degradation caused by thermal expansion and contraction and high temperature oxidation.
- Ceramic fiber products shrink at high temperatures. During the first 24 hours of operation at

temperatures between 1600 and 2200°F (870 to 1204°C) shrinkage of up to four percent can occur. Fill all gaps between units created by shrinkage with loose ceramic fiber insulation. Watlow offers a “pre-firing” process that pre-shrinks and dimensionally stabilizes units before shipping. Consult the factory for further details.

- Use additional back-up insulation for maximum energy efficiency and appropriate safety considerations. Use only insulation with inorganic fibers and binders to avoid corrosive fumes that could damage heater elements.
- Handle all units and leads with care. Ceramic fiber heaters are very resistant to thermal cycling and thermal shock, but are easily subjected to mechanical damage from careless handling.
- Repair of minor mechanical damage, made with unapproved or unknown cements, could cause damage to the wire elements at high temperatures. If unsure, consult the factory before making any repairs. Several accessory items are available from the factory for repair purposes.

Ordering Hints

Ordering ceramic fiber heaters is easy. However, it's very important to pay attention to code numbers and special modifications details.

- Always fill in the “..._...” (blank) code position with the correct Type number (see illustrations above the charts).
- Always provide the correct Lead Style letter. (See suggested illustrations above the charts, but remember, the Style A-12 will be the default lead if not otherwise specified.)

- Supply drawing or sketches whenever possible. These reduce confusion.
- When ordering Type 6, 7, 8 units, be certain of the heated area and no-heat area orientations desired.
- When planning to order the non-stocked Type 2 and/or Type 3 units (left or right vestibule), there are three options to consider, two of which could be used on the Type 1 stocked items:
 1. Order the appropriate stocked full vestibule unit and the

- customer carefully removes the unneeded vestibule themselves.
2. Order the stocked full vestibule unit and, prior to shipping, have Watlow remove the unneeded vestibule, as a stock modification. There is a small additional charge for this.
3. Special order the desired Type 2 or 3 unit. This requires custom manufacturing the heater and will increase delivery time, but will keep costs to a minimum.

Ceramic Fiber Products

F.O.B.: Columbia, Missouri

Ceramic Fiber Heaters

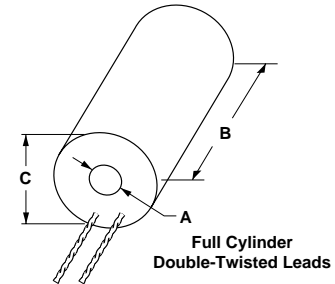

Full Cylinder Units

Dimensions, inches (mm)			Electrical Ratings			Lead Width	Approx. Net Wt. (oz (kg))	Availability	Code No.
Heated Area		Overall	Volts	Power (Watts) ±5%	Surface Loading ① (W/in ² (W/cm ²))				
I.D. (A) inches (mm) ±1/16 (±1.6)	Length (B) inches (mm) ±1/16 (±1.6)	O.D. (C) inches (mm) ±1/8 (±3.2)							
1/2 (13)	6 (152)	2 (51)	60	175	18.6 (2.9)	Double Twisted Leads	5 (0.14)	Stock	VC400J06A
1/2 (13)	12 (305)	2 (51)	120	350	18.6 (2.9)		10 (0.28)	Stock	VC400J12A
3/4 (19)	6 (152)	3 (76)	60	200	14.2 (2.2)		8 (0.23)	Stock	VC400N06A
3/4 (19)	12 (305)	3 (76)	120	400	14.2 (2.2)		13 (0.37)	Stock	VC400N12A
1 (25)	6 (152)	3 (76)	60	220	11.7 (1.8)		9 (0.26)	Stock	VC401A06A
1 (25)	12 (305)	3 (76)	120	440	11.7 (1.8)		13 (0.37)	Stock	VC401A12A
1 1/4 (32)	6 (152)	3 1/2 (89)	60	275	11.7 (1.8)		11 (0.31)	Stock	VC401E06A
1 1/4 (32)	12 (305)	3 1/2 (89)	120	550	11.7 (1.8)		18 (0.51)	Stock	VC401E12A
1 1/2 (38)	6 (152)	3 1/2 (89)	60	300	10.6 (1.6)		12 (0.34)	Stock	VC401J06A
1 1/2 (38)	12 (305)	3 1/2 (89)	120	600	10.6 (1.6)		20 (0.57)	Stock	VC401J12A
1 3/4 (45)	6 (152)	4 (102)	120	350	10.6 (1.6)		12 (0.34)	Stock	VC401N06A
1 3/4 (45)	12 (305)	4 (102)	120	700	10.6 (1.6)		23 (0.65)	Stock	VC401N12A
2 (51)	6 (152)	4 (102)	120	425	11.3 (1.8)		13 (0.37)	Stock	VC402A06A
2 (51)	12 (305)	4 (102)	120	850	11.3 (1.8)		25 (0.71)	Stock	VC402A12A

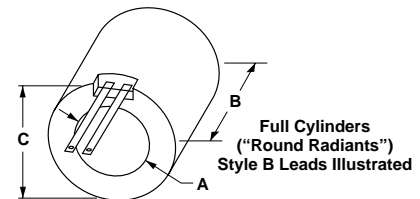
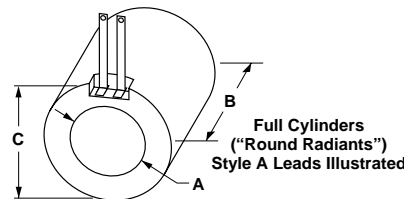

Full Cylinder Units

Dimensions, inches (mm)			Electrical Ratings			Lead Width inches (mm)	Approx. Net Wt. (lbs (kg))	Availability	Code No.
Heated Area		Overall	Volts	Power (Watts) ±5%	Surface Loading ① (W/in ² (W/cm ²))				
I.D. (A) inches (mm) ±1/16 (±1.6)	Length (B) inches (mm) ±1/16 (±1.6)	O.D. (C) inches (mm) ±1/8 (±3.2)							
3 (76)	6 (152)	7 (178)	120	650	11.5 (1.8)	3/8 (10)	2.5 (1.1)	Stock	VC403A06A
4 (102)	6 (152)	8 (203)	120	900	11.9 (1.8)	1/2 (13)	3.1 (1.4)	Stock	VC404A06A
4 (102)	6 (152)	8 (203)	120	1100	14.6 (2.3)	3/8 (10)	3.1 (1.4)	Stock	VC404A06T
5 (127)	6 (152)	9 (229)	120	1250	13.7 (2.1)	1/2 (13)	3.5 (1.6)	Stock	VC405A06A
5 (127)	6 (152)	9 (229)	120	1400	14.9 (2.3)	3/8 (10)	3.6 (1.6)	Stock	VC405A06T
6 1/2 (165)	6 (152)	10 1/2 (267)	120	1500	12.2 (1.9)	3/4 (19)	4.9 (2.2)	Stock	VC406J06A
6 1/2 (165)	6 (152)	10 1/2 (267)	120	2000	16.3 (2.5)	1/2 (13)	4.9 (2.2)	Stock	VC406J06T
8 (203)	6 (152)	12 (305)	120	1800	11.9 (1.8)	3/4 (19)	5.7 (2.6)	Stock	VC408A06A
8 (203)	6 (152)	12 (305)	120	2600	17.2 (2.7)	3/4 (19)	5.8 (2.6)	Stock	VC408A06T

For unheated insulation tubes, substitute "VN" for "VC" in the code number of the appropriate size unit.

① Units with code numbers ending in ...0A, watt densities between 10.6 to 14.2 W/in² (1.6 to 2.2 W/cm²), are coil designs that are suitable for use up to 2000°F (1093°C) maximum surface temperature. Units with code numbers ending in ...T, watt densities between 14.6 to 17.2 W/in² (2.3 to 2.7 W/cm²), are "round radiants" with sinuated element designs and the high emissivity coating, and are suitable for use to 1800°F (982°C) maximum surface temperature.

Ceramic Fiber Products

Ceramic Fiber Heaters

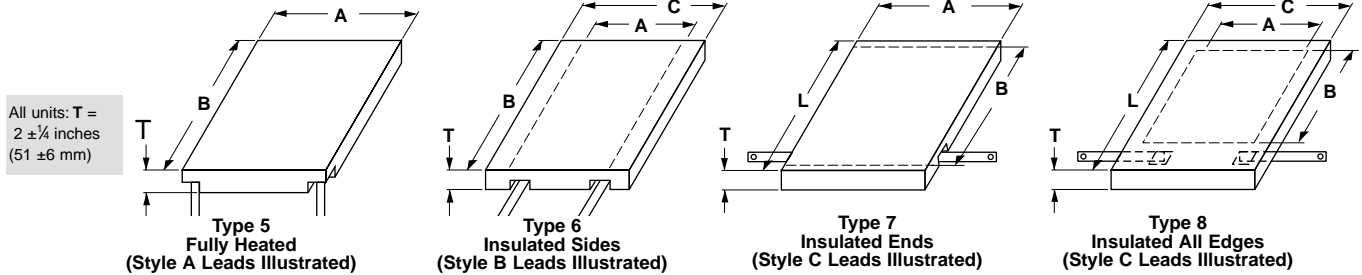

All units: T = 2 ± ¼ inches (51 ± 6 mm)

(Style A, B or C leads available on any type unit. Please specify.)

Flat Units — Embedded Coiled Elements (see page 142)

Dimensions, inches (mm)				Electrical Rating			Strip Lead Width in (mm)	Approximate Net Wt.			Avail.	Code No.
Type 5 Heated Size		Type 6 & 8		Volts	Power (Watts) ±5%	Surface Loading W/in ² (W/cm ²)		Type 5	Type 6 & 7	Type 8		
Width (A) in (mm) +½ - ⅛ (1.6-3.2)	Length (B) in (mm) +½ - ⅛ (1.6-3.2)	Width (C) in (mm) +½ - ⅛ (1.6-3.2)	Length (L) in (mm) +½ - ⅛ (1.6-3.2)				lbs (kg)	lbs (kg)	lbs (kg)			
4 (102)	6 (152)	8 (203)	10 (254)	60	275	11.5 (1.8)	⅜ (10)	0.6 (0.3)	1.1 (0.5)	1.7 (0.8)	Stock	VF04A06S
	12 (305)	8 (203)	16 (406)	60	550	11.5 (1.8)	½ (13)	1.2 (0.5)	2.2 (1.0)	2.8 (1.3)	Stock	VF_04A12S
	18 (457)	8 (203)	22 (559)	120	750	10.4 (1.6)	⅝ (10)	1.9 (0.9)	3.4 (1.5)	4.5 (2.0)	Standard	VF_04A18S
	24 (610)	8 (203)	28 (711)	120	1100	11.5 (1.8)	¾ (13)	2.4 (1.1)	4.4 (2.0)	5.6 (2.5)	Stock	VF_04A24S
6 (152)	6 (152)	10 (254)	10 (254)	60	375	10.4 (1.6)	⅜ (10)	0.9 (0.4)	1.5 (0.7)	2.4 (1.1)	Stock	VF_06A06S
	12 (305)	10 (254)	16 (406)	120	750	10.4 (1.6)	⅜ (10)	1.8 (0.8)	2.8 (1.3)	3.7 (1.7)	Stock	VF_06A12S
	18 (457)	10 (254)	22 (559)	120	1250	11.6 (1.8)	½ (13)	3.0 (1.4)	4.1 (1.9)	5.0 (2.3)	Stock	VF_06A18S
	24 (610)	10 (254)	28 (711)	240	1500	10.4 (1.6)	⅝ (10)	3.5 (1.6)	5.3 (2.4)	6.2 (2.8)	Stock	VF_06A24S
	30 (762)	10 (254)	34 (864)	240	2000	11.2 (1.7)	½ (13)	4.5 (2.0)	6.6 (3.0)	8.4 (3.8)	Standard	VF_06A30S
	36 (914)	10 (254)	40 (1016)	240	2500	11.6 (1.8)	¾ (13)	6.1 (2.8)	8.3 (3.8)	10.2 (4.6)	Standard	VF_06A36S
8 (203)	12 (305)	12 (305)	16 (406)	120	1100	11.5 (1.8)	½ (13)	2.5 (1.1)	3.2 (1.5)	4.1 (1.9)	Stock	VF_08A12S
	18 (457)	12 (305)	22 (559)	240	1500	10.4 (1.6)	⅝ (10)	3.6 (1.6)	4.7 (2.1)	5.6 (2.5)	Stock	VF_08A18S
	24 (610)	12 (305)	28 (711)	240	2200	11.5 (1.8)	¾ (13)	4.8 (2.2)	6.5 (2.9)	7.4 (3.4)	Stock	VF_08A24S
	30 (762)	12 (305)	34 (864)	240	2500	10.4 (1.6)	½ (13)	6.2 (2.8)	8.0 (3.6)	9.7 (4.4)	Standard	VF_08A30S
	36 (914)	12 (305)	40 (1016)	240	3000	10.4 (1.6)	¾ (19)	7.8 (3.5)	10.0 (4.5)	11.8 (5.4)	Standard	VF_08A36S
10 (254)	12 (305)	14 (356)	16 (406)	240	1250	10.4 (1.6)	⅜ (10)	2.6 (1.2)	3.9 (1.8)	5.0 (2.3)	Stock	VF_10A12S
	18 (457)	14 (356)	22 (559)	240	1800	10.0 (1.6)	½ (13)	4.2 (1.9)	5.4 (2.4)	6.5 (2.9)	Stock	VF_10A18S
	24 (610)	14 (356)	28 (711)	240	2500	10.4 (1.6)	½ (13)	5.2 (2.4)	7.7 (3.5)	8.8 (4.0)	Standard	VF_10A24S
	30 (762)	14 (356)	34 (864)	240	3000	10.0 (1.6)	¾ (19)	7.0 (3.2)	9.5 (4.3)	11.7 (5.3)	Stock	VF_10A30S
	36 (914)	14 (356)	40 (1016)	240	3600	10.0 (1.6)	¾ (19)	9.1 (4.1)	11.5 (5.2)	13.7 (6.2)	Standard	VF_10A36S
12 (305)	12 (305)	16 (406)	16 (406)	240	1500	10.4 (1.6)	⅜ (10)	3.2 (1.5)	4.6 (2.1)	5.8 (2.6)	Stock	VF_12A12S
	18 (457)	16 (406)	22 (559)	240	2200	10.2 (1.6)	½ (13)	4.9 (2.2)	6.5 (2.9)	7.7 (3.5)	Stock	VF_12A18S
	24 (610)	16 (406)	28 (711)	240	3000	10.4 (1.6)	¾ (19)	7.5 (3.4)	9.5 (4.3)	10.7 (4.9)	Stock	VF_12A24S
	30 (762)	16 (406)	34 (864)	240	3600	10.0 (1.6)	¾ (19)	9.1 (4.1)	11.7 (5.3)	12.9 (5.9)	Standard	VF_12A30S
	36 (914)	16 (406)	40 (1016)	240	4400	10.2 (1.6)	¾ (19)	12.4 (5.6)	15.5 (7.0)	16.7 (7.6)	Standard	VF_12A36S
14 (356)	12 (305)	18 (457)	16 (406)	240	1750	10.4 (1.6)	½ (13)	4.7 (2.1)	6.1 (2.8)	7.6 (3.4)	Standard	VF_14A12S
	18 (457)	18 (457)	22 (559)	240	2550	10.6 (1.6)	½ (13)	6.8 (3.1)	8.5 (3.9)	10.0 (4.5)	Standard	VF_14A18S
	24 (610)	18 (457)	28 (711)	240	3500	10.4 (1.6)	¾ (19)	10.0 (4.5)	11.9 (5.4)	13.4 (6.1)	Stock	VF_14A24S
	30 (762)	18 (457)	34 (864)	240	4300	10.2 (1.6)	¾ (19)	12.5 (5.7)	15.0 (6.8)	16.5 (7.5)	Standard	VF_14A30S
	36 (914)	18 (457)	40 (1016)	240/240	5200	10.3 (1.6)	¾ (19)	14.2 (6.4)	17.2 (7.8)	18.7 (8.5)	Standard	VF_14A36S ²
16 (406)	12 (305)	20 (508)	16 (406)	240	2100	10.9 (1.7)	½ (13)	5.2 (2.4)	6.7 (3.0)	8.4 (3.8)	Standard	VF_16A12S
	18 (457)	20 (508)	22 (559)	240	3000	10.4 (1.6)	¾ (19)	8.2 (3.7)	9.9 (4.5)	11.6 (5.3)	Standard	VF_16A18S
	24 (610)	20 (508)	28 (711)	240	4200	10.9 (1.7)	¾ (19)	11.9 (5.4)	13.8 (6.3)	15.5 (7.0)	Standard	VF_16A24S
	30 (762)	20 (508)	34 (864)	240/240	5000	10.4 (1.6)	¾ (19)	15.2 (6.9)	17.7 (8.0)	19.4 (8.8)	Standard	VF_16A30S ²
	36 (914)	20 (508)	40 (1016)	240/240	6000	10.4 (1.6)	¾ (19)	17.9 (8.1)	20.9 (9.5)	22.6 (10.3)	Standard	VF_16A36S ²

① Add Type number (Type 5 - 8) in the blank position in the code number. Example: VF704A06S. For unheated units, see catalog page 146. All units in this table are suitable for use up to 2000°F (1093°C) maximum surface temperature.

② These units have dual elements, to be used in "parallel" for 240 volt usage. Alternate designs are available for 480 volt, 277 volt and three phase (internally wired). Consult factory.

Ceramic Fiber Products

Ceramic Fiber Heaters

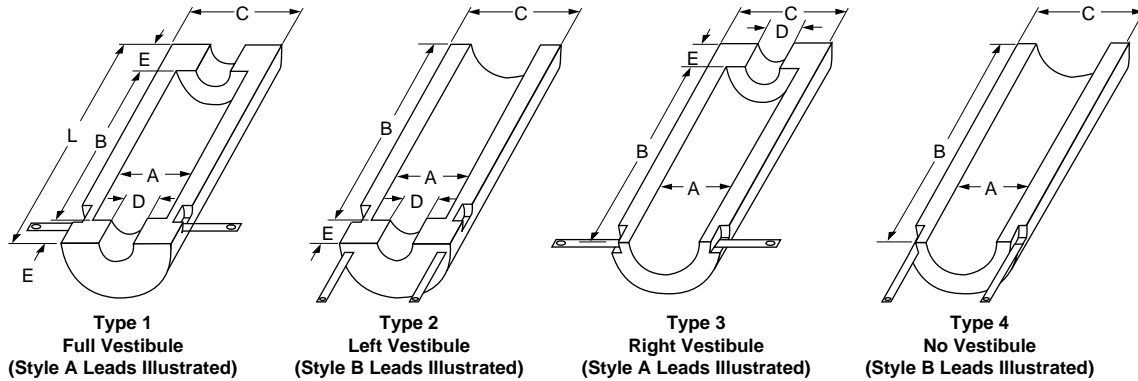

(Style A or B leads available on any type unit. Please specify.)

Semi-Cylindrical Units — Embedded Coiled Elements (see page 142)

Dimensions, inches (mm)						Electrical Ratings			Approx. Net Wt.		Avail.	Code No.	
Type 4 Heater Size			Type 1, 2, & 3 Sizes			Volts	Power (Watts) ±5%	Surface Loading W/in ² (W/cm ²)	Strip Lead Width in (mm)	Type 1 Full Vest.			Type 4 No Vest.
I.D. (A) in (mm) ±½ (±3.2)	Length (B) in (mm) +¼ - ½ (+1.6 - 3.2)	O.D. (C) in (mm) (Ref)	Vestibule Sizes							Type 1 Full Vest. lbs (kg)	Type 4 No Vest. lbs (kg)		
			Length (L) in (mm) +¼ - ½ (+1.6 - 3.2)	Dia. (D) in (mm) ±½ (±3.2)	Length (E) in (mm) +¼ - ½ (+1.6 - 3.2)								
2 (51)	6 (152)	6 (152)	8 (203)	1 (25)	1 (25)	60	275	14.6 (2.3)	¾ (10)	1.1 (0.5)	1.1 (0.5)	Stock	VS_02A06S
	12 (305)	6 (152)	14 (356)	1 (25)	1 (25)	120	550	14.6 (2.3)	¾ (10)	1.8 (0.8)	1.8 (0.8)	Stock	VS_02A12S
	18 (457)	6 (152)	20 (508)	1 (25)	1 (25)	120	750	13.3 (2.1)	¾ (10)	2.3 (1.0)	2.3 (1.0)	Stock	VS_02A18S
	24 (610)	6 (152)	26 (660)	1 (25)	1 (25)	240	1100	14.6 (2.3)	¾ (10)	3.5 (1.6)	3.5 (1.6)	Stock	VS_02A24S
3 ½ (89)	6 (152)	7 ½ (191)	9 ½ (241)	2 (51)	1 ¾ (45)	60	450	13.6 (2.1)	½ (13)	2.0 (0.9)	1.5 (0.7)	Stock	VS_03J06S
	12 (305)	7 ½ (191)	15 ½ (394)	2 (51)	1 ¾ (45)	120	900	13.6 (2.1)	½ (13)	3.1 (1.4)	2.6 (1.2)	Stock	VS_03J12S
	18 (457)	7 ½ (191)	21 ½ (546)	2 (51)	1 ¾ (45)	120	1250	12.6 (2.0)	½ (13)	4.5 (2.0)	4.0 (1.8)	Stock	VS_03J18S
	24 (610)	7 ½ (191)	27 ½ (699)	2 (51)	1 ¾ (45)	240	1800	13.6 (2.1)	½ (13)	5.4 (2.4)	4.9 (2.2)	Stock	VS_03J24S
5 (127)	6 (152)	9 (229)	11 (279)	3 ½ (89)	2 ½ (64)	60	625	13.3 (2.1)	½ (13)	3.4 (1.5)	2.5 (1.1)	Stock	VS_05A06S
	12 (305)	9 (229)	17 (432)	3 ½ (89)	2 ½ (64)	120	1250	13.3 (2.1)	½ (13)	4.9 (2.2)	4.0 (1.8)	Stock	VS_05A12S
	18 (457)	9 (229)	23 (584)	3 ½ (89)	2 ½ (64)	240	1775	12.6 (2.0)	½ (13)	5.7 (2.6)	4.8 (2.2)	Stock	VS_05A18S
	24 (610)	9 (229)	29 (737)	3 ½ (89)	2 ½ (64)	240	2500	13.3 (2.1)	½ (13)	7.9 (3.6)	6.9 (3.1)	Stock	VS_05A24S
	30 (762)	9 (229)	35 (889)	3 ½ (89)	2 ½ (64)	240	3100	13.2 (2.0)	¾ (19)	10.9 (4.9)	9.2 (4.2)	Stock	VS_05A30S
	36 (914)	9 (229)	41 (1041)	3 ½ (89)	2 ½ (64)	240	3550	12.6 (2.0)	¾ (19)	13.2 (6.0)	11.5 (5.2)	Standard	VS_05A36S
6 ½ (165)	6 (152)	10 ½ (267)	12 (305)	5 (127)	3 (76)	120	750	12.2 (1.9)	¾ (19)	3.8 (1.7)	2.6 (1.2)	Stock	VS_06J06S
	12 (305)	10 ½ (267)	18 (457)	5 (127)	3 (76)	240	1500	12.2 (1.9)	¾ (19)	5.4 (2.4)	4.2 (1.9)	Stock	VS_06J12S
	18 (457)	10 ½ (267)	24 (610)	5 (127)	3 (76)	240	2100	11.4 (1.8)	¾ (19)	7.5 (3.4)	6.2 (2.8)	Stock	VS_06J18S
	24 (610)	10 ½ (267)	30 (762)	5 (127)	3 (76)	240	3000	12.2 (1.9)	¾ (19)	10.9 (4.9)	8.9 (4.0)	Stock	VS_06J24S
	30 (762)	10 ½ (267)	36 (914)	5 (127)	3 (76)	240	3750	12.2 (1.9)	¾ (19)	13.5 (6.1)	11.4 (5.2)	Standard	VS_06J30S
	36 (914)	10 ½ (267)	42 (1067)	5 (127)	3 (76)	240	4200	11.4 (1.8)	¾ (19)	16.4 (7.4)	14.3 (6.5)	Standard	VS_06J36S
8 (203)	6 (152)	12 (305)	12 (305)	6 ½ (165)	3 (76)	120	900	11.6 (1.8)	½ (13)	5.0 (2.3)	2.8 (1.3)	Standard	VS_08A06S
	12 (305)	12 (305)	18 (457)	6 ½ (165)	3 (76)	240	1800	11.6 (1.8)	½ (13)	7.6 (3.4)	5.0 (2.3)	Stock	VS_08A12S
	18 (457)	12 (305)	24 (610)	6 ½ (165)	3 (76)	240	2500	11.1 (1.7)	½ (13)	10.5 (4.8)	8.1 (3.7)	Stock	VS_08A18S
	24 (610)	12 (305)	30 (762)	6 ½ (165)	3 (76)	240	3500	11.6 (1.8)	¾ (19)	13.9 (6.3)	12.4 (5.6)	Standard	VS_08A24S
	30 (762)	12 (305)	36 (914)	6 ½ (165)	3 (76)	240	4200	11.1 (1.7)	¾ (19)	16.6 (7.5)	14.1 (6.4)	Standard	VS_08A30S
	36 (914)	12 (305)	42 (1067)	6 ½ (165)	3 (76)	240/240	5000	11.1 (1.7)	½ (13)	18.0 (8.2)	15.6 (7.1)	Standard	VS_08A36S [®]

CONTINUED

① Add Type number (Type 1 - 4) in the blank position in the code number. Example: **VS102A06S**. For unheated units, see catalog page 146. Overall length applies only to the full vestibule (Type 1) Units. Types 2 and 3 are shorter by one vestibule length. Type 4 length equals (B). Type 2 (left vestibule) and Type 3 (right vestibule) style units are not stocked. They are, however still standard units, and designs are kept on file. All units have 2 ±¼ inch thick walls.

All units in this table are suitable for use up to **2000°F (1093°C)** maximum surface temperature.

② These units have dual elements, to be used in "parallel" for 240 volt usage. Alternate designs are available for 480 volt, 277 volt and three phase (internally wired). Consult factory.

Ceramic Fiber Products

Ceramic Fiber Heaters

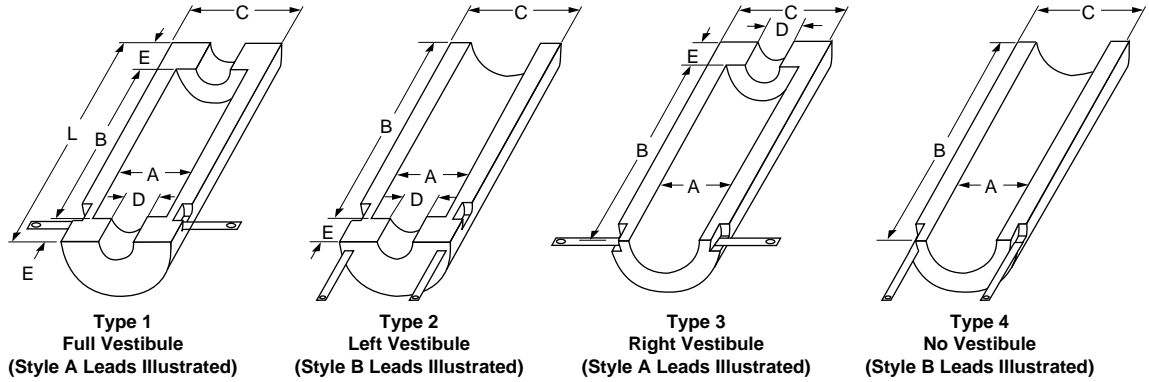

(Style A or B leads available on any type unit. Please specify.)

Semi-Cylindrical Units — Embedded Coiled Elements (see page 142)

Dimensions, inches (mm)						Electrical Ratings				Approx. Net Wt.		Avail.	Code No.	
Type 4 Heater Size			Type 1, 2, & 3 Sizes			Volts	Power (Watts) ±5%	Surface Loading W/in ² (W/cm ²)	Strip Lead Width in (mm)	Type 1 Full Vest.				Type 4 No Vest.
I.D. (A) in (mm) ±½ (±3.2)	Length (B) in (mm) +½ -½ (+1.6 - 3.2)	O.D. (C) in (mm) (Ref)	Vestibule Sizes							lbs (kg)	lbs (kg)			
			Length (L) in (mm) +½ -½ (+1.6 - 3.2)	Dia. (D) in (mm) ±½ (±3.2)	Length (E) in (mm) +½ -½ (+1.6 - 3.2)									
10 (254)	12 (305)	14 (356)	18 (457)	8 (203)	3 (76)	240	2100	11.1 (1.7)	½ (13)	9.2 (4.2)	6.5 (2.9)	Standard	VS[ⓐ]10A12S	
	18 (457)	14 (356)	24 (610)	8 (203)	3 (76)	240	3000	10.6 (1.6)	¾ (19)	13.3 (6.0)	10.6 (4.8)	Standard	VS_10A18S	
	24 (610)	14 (356)	30 (762)	8 (203)	3 (76)	240	4200	11.1 (1.7)	¾ (19)	15.5 (7.0)	12.8 (5.8)	Standard	VS_10A24S	
	30 (762)	14 (356)	36 (914)	8 (203)	3 (76)	240/240	5000	10.6 (1.6)	½ (13)	18.7 (8.5)	15.4 (7.0)	Standard	VS_10A30S[Ⓢ]	
	36 (914)	14 (356)	42 (1067)	8 (203)	3 (76)	240/240	6000	10.6 (1.6)	¾ (19)	22.6(10.3)	19.3 (8.8)	Standard	VS_10A36S[Ⓢ]	
12 (305)	12 (305)	16 (406)	18 (457)	10 (254)	3 (76)	240	2500	11.1 (1.7)	½ (13)	9.9 (4.5)	6.8 (3.1)	Stock	VS_12A12S	
	18 (457)	16 (406)	24 (610)	10 (254)	3 (76)	240	3500	10.3 (1.6)	¾ (19)	13.0 (5.9)	9.9 (4.5)	Stock	VS_12A18S	
	24 (610)	16 (406)	30 (762)	10 (254)	3 (76)	240	4200	9.3 (1.4)	¾ (19)	18.5 (8.4)	15.4 (7.0)	Stock	VS_12A24S	
	30 (762)	16 (406)	36 (914)	10 (254)	3 (76)	240/240	6000	10.6 (1.6)	¾ (19)	22.5(10.2)	18.6 (8.4)	Standard	VS_12A30S[Ⓢ]	
	36 (914)	16 (406)	42 (1067)	10 (254)	3 (76)	240/240	7000	10.3 (1.6)	¾ (19)	26.9(12.2)	23.1(10.5)	Standard	VS_12A36S[Ⓢ]	
14 (356)	12 (305)	18 (457)	18 (457)	12 (305)	3 (76)	240	3000	11.4 (1.8)	¾ (19)	12.6 (5.7)	9.0 (4.1)	Standard	VS_14A12S	
	18 (457)	18 (457)	24 (610)	12 (305)	3 (76)	240	4200	10.6 (1.6)	¾ (19)	15.3 (6.9)	11.7 (5.3)	Standard	VS_14A18S	
	24 (610)	18 (457)	30 (762)	12 (305)	3 (76)	240/240	6000	11.4 (1.8)	¾ (19)	18.8 (8.5)	15.2 (6.9)	Standard	VS_14A24S[Ⓢ]	
	30 (762)	18 (457)	36 (914)	12 (305)	3 (76)	240/240	7000	10.6 (1.6)	¾ (19)	26.7(12.1)	22.2(10.1)	Standard	VS_14A30S[Ⓢ]	
	36 (914)	18 (457)	42 (1067)	12 (305)	3 (76)	240/240	8400	10.6 (1.6)	¾ (19)	31.8(14.4)	27.3(12.4)	Standard	VS_14A36S[Ⓢ]	
16 (406)	12 (305)	20 (508)	18 (457)	14 (356)	3 (76)	240	3500	11.6 (1.8)	¾ (19)	14.0 (6.4)	10.2 (4.6)	Standard	VS_16A12S	
	18 (457)	20 (508)	24 (610)	14 (356)	3 (76)	240	4200	9.3 (1.4)	¾ (19)	16.9 (7.7)	13.1 (5.9)	Standard	VS_16A18S	
	24 (610)	20 (508)	30 (762)	14 (356)	3 (76)	240/240	7000	11.6 (1.8)	¾ (19)	20.8 (9.4)	17.0 (7.7)	Standard	VS_16A24S[Ⓢ]	
	30 (762)	20 (508)	36 (914)	14 (356)	3 (76)	240/240	7600	10.1 (1.6)	¾ (19)	30.1(13.7)	24.2(11.0)	Standard	VS_16A30S[Ⓢ]	
	36 (914)	20 (508)	42 (1067)	14 (356)	3 (76)	240/240	9000	9.9 (1.5)	¾ (19)	34.4(15.6)	28.5(12.9)	Standard	VS_16A36S[Ⓢ]	

ⓐ Add Type number (Type 1 - 4) in the blank position in the code number. Example: **VS102A06S**. For unheated units, see catalog page 146. Overall length applies only to the full vestibule (Type 1) Units. Types 2 and 3 are shorter by one vestibule length. Type 4 length equals (B). Type 2 (left vestibule) and Type 3 (right vestibule) style units are not stocked. They are, however still standard units, and designs are kept on file. All units have 2 ±¼ inch thick walls.

All units in this table are suitable for use up to **2000°F (1093°C)** maximum surface temperature.

Ⓢ These units have dual elements, to be used in "parallel" for 240 volt usage. Alternate designs are available for 480 volt, 277 volt and three phase (internally wired). Consult factory.

Ceramic Fiber Products

Ceramic Fiber Heaters

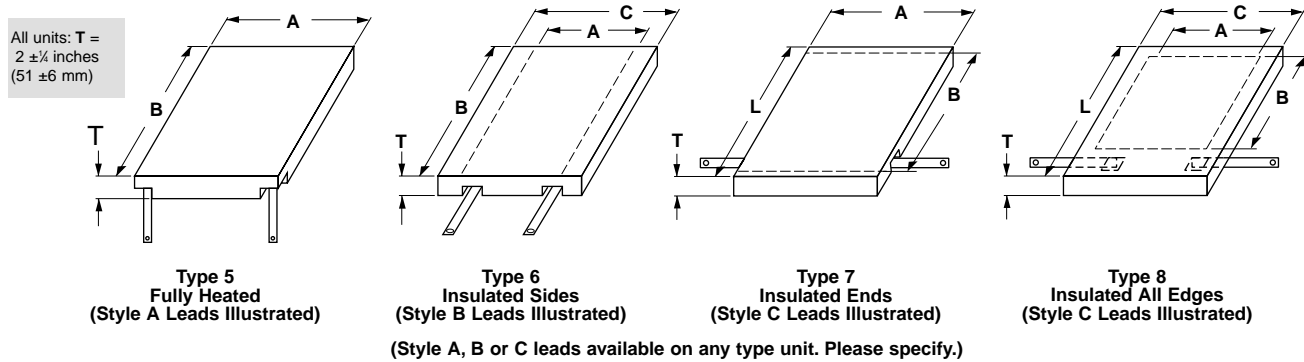

Flat Units—High Watt Density Sinuated Elements (see page 142)

Dimensions, inches (mm)				Electrical Rating			Strip Lead Width in (mm)	Approximate Net Wt.			Avail.	Code No.
Type 5 Heated Size		Type 6 & 8	Type 7 & 8	Volts	Power (Watts) ±5%	Surface Loading W/in ² (W/cm ²)		Type 5	Type 6 & 7	Type 8		
Width (A) in (mm) +1/8 - 1/8 (1.6-3.2)	Length (B) in (mm) +1/8 - 1/8 (1.6-3.2)	Width (C) in (mm) +1/8 - 1/8 (1.6-3.2)	Length (L) in (mm) +1/8 - 1/8 (1.6-3.2)				lbs (kg)	lbs (kg)	lbs (kg)			
6 (152)	12 (305)	10 (254)	16 (406)	60	1250	17.4 (2.7)	1/2 (13)	1.7 (0.8)	2.7 (1.6)	3.6 (1.2)	Standard	VF [Ⓢ] 06A12T
	18 (457)	10 (254)	22 (559)	120	2000	18.5 (2.9)	1/2 (13)	2.6 (1.2)	3.7 (2.1)	4.6 (1.7)	Standard	VF_06A18T
	24 (610)	10 (254)	28 (711)	120	2500	17.4 (2.7)	1/2 (13)	3.2 (1.5)	5.0 (2.7)	5.9 (2.3)	Stock	VF_06A24T
	24 (610)	10 (254)	28 (711)	240	2500	17.4 (2.7)	1/2 (13)	3.2 (1.5)	5.0 (2.7)	5.9 (2.3)	Stock	VF_06A24U
	30 (762)	10 (254)	34 (864)	240	3400	18.9 (2.9)	1/2 (13)	4.5 (2.0)	7.1 (3.6)	7.9 (3.2)	Stock	VF_06A30T
	36 (914)	10 (254)	40 (1016)	240	4000	18.5 (2.9)	1/2 (13)	5.5 (2.5)	8.5 (4.2)	9.3 (3.9)	Standard	VF_06A36T
8 (203)	12 (305)	12 (305)	16 (406)	60	1800	18.7 (2.9)	3/4 (19)	2.3 (1.0)	3.0 (1.8)	3.9 (1.4)	Stock	VF_08A12T
	18 (457)	12 (305)	22 (559)	120	3000	20.8 (3.2)	3/4 (19)	3.5 (1.6)	4.6 (2.5)	5.5 (2.1)	Stock	VF_08A18T
	24 (610)	12 (305)	28 (711)	120	3600	18.7 (2.9)	3/4 (19)	4.4 (2.0)	6.1 (3.2)	7.0 (2.8)	Stock	VF_08A24T
	30 (762)	12 (305)	34 (864)	240	5000	20.8 (3.2)	1/2 (13)	6.1 (2.8)	8.7 (4.4)	9.7 (4.0)	Standard	VF_08A30T
	36 (914)	12 (305)	40 (1016)	240	6000	20.8 (3.2)	3/4 (19)	7.0 (3.2)	10.0 (5.0)	11.0 (4.5)	Standard	VF_08A36T
	10 (254)	12 (305)	14 (356)	16 (406)	120	2000	16.7 (2.6)	1/2 (13)	2.4 (1.1)	3.7 (2.2)	4.8 (1.7)	Stock
18 (457)		14 (356)	22 (559)	120	3600	20.0 (3.1)	3/4 (19)	4.0 (1.8)	5.2 (2.9)	6.3 (2.4)	Stock	VF_10A18T
24 (610)		14 (356)	28 (711)	240	4500	17.9 (2.8)	3/4 (19)	4.7 (2.1)	7.2 (3.8)	8.3 (3.3)	Stock	VF_10A24T
30 (762)		14 (356)	34 (864)	240	6000	20.0 (3.1)	3/4 (19)	6.7 (3.0)	9.3 (4.8)	10.5 (4.2)	Standard	VF_10A30T
36 (914)		14 (356)	40 (1016)	240	7200	20.0 (3.1)	3/4 (19)	8.5 (3.9)	11.5 (5.8)	12.7 (5.2)	Standard	VF_10A36T
12 (305)		12 (305)	16 (406)	16 (406)	120	2500	17.4 (2.7)	1/2 (13)	2.9 (1.3)	4.3 (2.5)	5.5 (2.0)	Stock
	12 (305)	16 (406)	16 (406)	240	2500	17.4 (2.7)	3/4 (19)	2.9 (1.3)	4.3 (2.5)	5.5 (2.0)	Stock	VF_12A12U
	18 (457)	16 (406)	22 (559)	240	4000	18.5 (2.9)	1/2 (13)	4.5 (2.0)	6.1 (3.3)	7.3 (2.8)	Stock	VF_12A18T
	24 (610)	16 (406)	28 (711)	240	6000	20.8 (3.2)	3/4 (19)	6.6 (3.0)	8.6 (4.4)	9.8 (3.9)	Stock	VF_12A24T
	30 (762)	16 (406)	34 (864)	240	7200	20.0 (3.1)	3/4 (19)	8.6 (3.9)	11.2 (5.7)	12.6 (5.1)	Standard	VF_12A30T
	36 (914)	16 (406)	40 (1016)	240/240	8400	19.4 (3.0)	3/4 (19)	10.2 (4.6)	13.2 (6.6)	14.6 (6.0)	Standard	VF_12A36T [Ⓢ]
14 (356)	12 (305)	18 (457)	16 (406)	120	3500	20.8 (3.2)	3/4 (19)	4.2 (1.9)	5.3 (3.0)	6.7 (2.4)	Standard	VF_14A12T
	18 (457)	18 (457)	22 (559)	240	4900	19.4 (3.0)	1/2 (13)	6.1 (2.8)	7.6 (4.1)	9.1 (3.4)	Standard	VF_14A18T
	24 (610)	18 (457)	28 (711)	240	7000	20.8 (3.2)	3/4 (19)	8.5 (3.9)	10.5 (5.4)	11.9 (4.8)	Standard	VF_14A24T
	30 (762)	18 (457)	34 (864)	240/240	8400	20.0 (3.1)	3/4 (19)	10.7 (4.9)	13.2 (6.6)	14.6 (6.0)	Standard	VF_14A30T [Ⓢ]
	36 (914)	18 (457)	40 (1016)	240/240	9800	19.4 (3.0)	1/2 (13)	12.2 (5.5)	15.2 (7.5)	16.6 (6.9)	Standard	VF_14A36T [Ⓢ]
	16 (406)	12 (305)	20 (508)	16 (406)	120	3550	18.5 (2.9)	3/4 (19)	4.7 (2.1)	5.7 (3.4)	7.4 (2.6)	Standard
18 (457)		20 (508)	22 (559)	240	5750	20.0 (3.1)	3/4 (19)	7.1 (3.2)	8.6 (4.7)	10.3 (3.9)	Standard	VF_16A18T
24 (610)		20 (508)	28 (711)	240	7100	18.5 (2.9)	3/4 (19)	9.5 (4.3)	11.5 (6.0)	13.2 (5.2)	Standard	VF_16A24T
30 (762)		20 (508)	34 (864)	240/240	9600	20.0 (3.1)	1/2 (13)	11.7 (5.3)	14.2 (7.2)	15.9 (6.4)	Standard	VF_16A30T [Ⓢ]
36 (914)		20 (508)	40 (1016)	240/240	11500	20.0 (3.1)	3/4 (19)	14.2 (6.4)	17.2 (8.6)	18.9 (7.8)	Standard	VF_16A36T [Ⓢ]

① Add Type number (Type 5 - 8) in the blank position in the code number. Example: VF[Ⓢ]06A12T. For unheated units, see catalog page 146.

Sinuated wire, high watt density units are provided with embedded sinuated elements and high emissivity coating, unless exposed sinuated is specified when manufactured. (These are **not stocked**.) Consult factory.

All units in this table are suitable for use up to **1800°F (982°C)** maximum surface temperature.

② These units have dual elements, to be used in "parallel" for 240 volt usage. Alternate designs are available for 480 volt, 277 volt and three phase (internally wired). Consult factory.

Ceramic Fiber Products

Ceramic Fiber Heaters

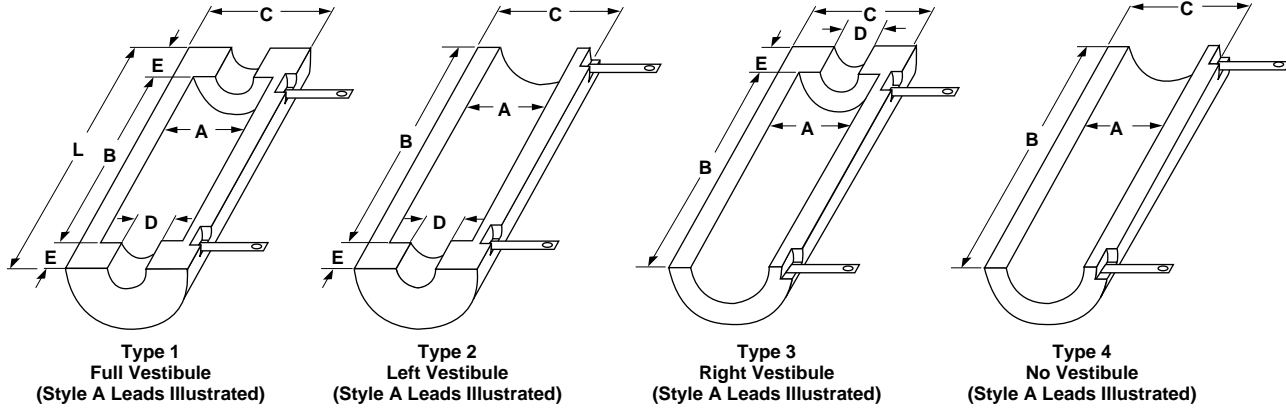

Ceramic Fiber Products

Semi-Cylindrical Units—High Watt Density Sinuated Elements (see page 142)

Dimensions, inches (mm)						Electrical Ratings			Approx. Net Wt.		Avail.	Code No.	
Type 4 Heater Size			Type 1, 2, & 3 Sizes			Volts	Power (Watts) ±5%	Surface Loading W/in ² (W/cm ²)	Strip Lead Width in (mm)	Type 1 Full Vest.			Type 4 No Vest.
I.D. (A) in (mm) ±½ (±3.2)	Length (B) in (mm) +¼ - ⅛ (1.6 - 3.2)	O.D. (C) in (mm) (Ref)	Vestibule Sizes							Type 1 Full Vest. lbs (kg)	Type 4 No Vest. lbs (kg)		
			Length (L) in (mm) +¼ - ⅛ (1.6 - 3.2)	Dia. (D) in (mm) ±½ (±3.2)	Length (E) in (mm) +¼ - ⅛ (1.6 - 3.2)								
5 (127)	6 (152)	9 (229)	11 (279)	3½ (89)	2½ (64)	60	750	15.9 (2.5)	¾ (10)	3.1 (1.4)	2.3 (1.0)	Standard	VS_005A06T
	12 (305)	9 (229)	17 (432)	3½ (89)	2½ (64)	60	1400	14.9 (2.3)	¾ (19)	4.5 (2.0)	3.6 (1.6)	Standard	VS_05A12T
	18 (457)	9 (229)	23 (584)	3½ (89)	2½ (64)	120	2100	14.9 (2.3)	½ (13)	5.2 (2.4)	4.3 (2.0)	Standard	VS_05A18T
	24 (610)	9 (229)	29 (737)	3½ (89)	2½ (64)	120	2800	14.9 (2.3)	¾ (19)	6.9 (3.1)	6.0 (2.7)	Standard	VS_05A24T
	30 (762)	9 (229)	35 (889)	3½ (89)	2½ (64)	240	3500	14.9 (2.3)	½ (13)	8.3 (3.8)	7.4 (3.4)	Standard	VS_05A30T
	36 (914)	9 (229)	41 (102)	3½ (89)	2½ (64)	240	4200	14.9 (2.3)	½ (13)	9.6 (4.4)	8.7 (3.9)	Standard	VS_05A36T
6½ (165)	6 (152)	10½ (267)	12 (305)	5 (127)	3 (76)	60	1000	16.3 (2.5)	½ (13)	3.6 (1.6)	2.4 (1.1)	Standard	VS_06J06T
	12 (305)	10½ (267)	18 (457)	5 (127)	3 (76)	120	2000	16.3 (2.5)	½ (13)	5.1 (2.3)	3.9 (1.8)	Standard	VS_06J12T
	18 (457)	10½ (267)	24 (610)	5 (127)	3 (76)	120	3000	16.3 (2.5)	¾ (19)	6.8 (3.1)	5.6 (2.5)	Standard	VS_06J18T
	24 (610)	10½ (267)	30 (762)	5 (127)	3 (76)	240	4000	16.3 (2.5)	½ (13)	9.5 (4.3)	7.4 (3.4)	Standard	VS_06J24T
	30 (762)	10½ (267)	36 (914)	5 (127)	3 (76)	240	5000	16.3 (2.5)	½ (13)	11.0 (5.0)	9.3 (4.2)	Standard	VS_06J30T
	36 (914)	10½ (267)	42 (1067)	5 (127)	3 (76)	240	6000	16.3 (2.5)	¾ (19)	12.4 (5.6)	11.2 (5.1)	Standard	VS_06J36T
8 (203)	6 (152)	12 (305)	12 (305)	6½ (165)	3 (76)	60	1300	17.2 (2.7)	½ (13)	4.1 (1.9)	2.6 (1.2)	Standard	VS_08A06T
	12 (305)	12 (305)	18 (457)	6½ (165)	3 (76)	120	2600	17.2 (2.7)	½ (13)	6.9 (3.1)	5.4 (2.4)	Standard	VS_08A12T
	18 (457)	12 (305)	24 (610)	6½ (165)	3 (76)	240	3900	17.2 (2.7)	½ (13)	8.5 (3.9)	7.0 (3.2)	Standard	VS_08A18T
	24 (610)	12 (305)	30 (762)	6½ (165)	3 (76)	240	5200	17.2 (2.7)	½ (13)	12.0 (5.4)	10.5 (4.8)	Standard	VS_08A24T
	30 (762)	12 (305)	36 (914)	6½ (165)	3 (76)	240	6250	16.7 (2.6)	¾ (19)	13.8 (6.3)	12.3 (5.6)	Standard	VS_08A30T
	36 (914)	12 (305)	42 (1067)	6½ (165)	3 (76)	240/240	7800	17.2 (2.7)	¾ (19)	15.6 (7.1)	14.1 (6.4)	Standard	VS_08A36T [Ⓜ]

CONTINUED

Ⓜ Add Type number (Type 1 - 4) in the blank position in the code number. Example: VS106J06T. For unheated units, see catalog page 146. Sinuated wire, high watt density units are provided with embedded sinuated elements and high emissivity coating, unless exposed sinuated is specified when manufactured. (These are **not stocked**.) Consult factory.

Overall length applies only to the full vestibule (Type 1) units. Types 2 and 3 are shorter by one vestibule length. Type 4 length equals (B). Type 2 (left vestibule) and Type 3 (right vestibule) style units are not stocked. They are, however, still standard units, and designs are kept on file. All units have 2 ±¼ inch thick walls.

All units in this table are suitable for use up to **1800°F (982°C)** maximum surface temperature.

Ⓜ These units have dual elements, to be used in "parallel" for 240 volt usage. Alternate designs are available for 480 volt, 277 volt and three phase (internally wired). Consult factory.

Ceramic Fiber Products

Ceramic Fiber Heaters

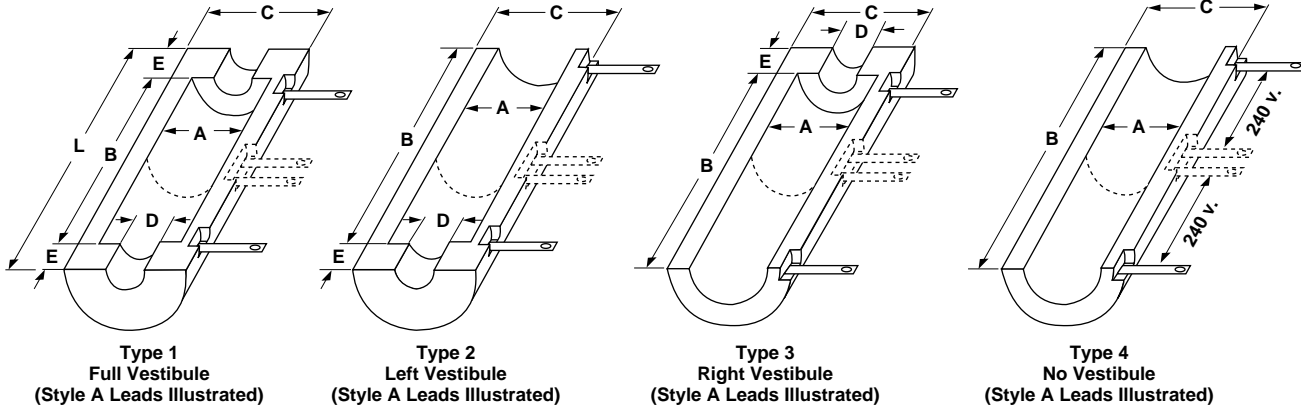

Semi-Cylindrical Units—High Watt Density Sinuated Elements (see page 142)

Dimensions, inches (mm)						Electrical Ratings			Strip Lead Width in (mm)	Approx. Net Wt.		Avail.	Code No.
Type 4 Heater Size			Type 1, 2, & 3 Sizes			Volts	Power (Watts) ±5%	Surface Loading W/in ² (W/cm ²)		Type 1 Full Vest. lbs (kg)	Type 4 No Vest. lbs (kg)		
I.D. (A) in (mm) ±1/8 (±3.2)	Length (B) in (mm) +1/16 -1/8 (+1.6 - 3.2)	O.D. (C) in (mm) (Ref)	Vestibule Sizes										
			Length (L) in (mm) +1/16 -1/8 (+1.6 - 3.2)	Dia. (D) in (mm) ±1/8 (±3.2)	Length (E) in (mm) +1/16 -1/8 (+1.6 - 3.2)								
10 (254)	12 (305)	14 (356)	18 (457)	8 (203)	3 (76)	240	3200	17.0 (2.6)	1/2 (13)	8.5 (3.9)	5.8 (2.6)	Standard	VS ^① 10A12T
	18 (457)	14 (356)	24 (610)	8 (203)	3 (76)	240	4800	17.0 (2.6)	1/2 (13)	12.0 (5.4)	9.3 (4.2)	Standard	VS_10A18T
	24 (610)	14 (356)	30 (762)	8 (203)	3 (76)	240	6400	17.0 (2.6)	3/4 (19)	13.8 (6.3)	11.1 (5.0)	Standard	VS_10A24T
	30 (762)	14 (356)	36 (914)	8 (203)	3 (76)	240/240	8000	17.0 (2.6)	3/4 (19)	17.6 (8.0)	14.9 (6.8)	Standard	VS_10A30T ^②
	36 (914)	14 (356)	42 (1067)	8 (203)	3 (76)	240/240	9600	17.0 (2.6)	1/2 (13)	21.3 (9.7)	18.6 (8.4)	Standard	VS_10A36T ^②
12 (305)	12 (305)	16 (406)	18 (457)	10 (254)	3 (76)	240	3800	16.8 (2.6)	1/2 (13)	8.9 (4.0)	5.9 (2.7)	Standard	VS_12A12T
	18 (457)	16 (406)	24 (610)	10 (254)	3 (76)	240	5700	16.8 (2.6)	3/4 (19)	11.2 (5.1)	8.1 (3.7)	Standard	VS_12A18T
	24 (610)	16 (406)	30 (762)	10 (254)	3 (76)	240	7600	16.8 (2.6)	3/4 (19)	16.7 (7.6)	13.6 (6.2)	Standard	VS_12A24T
	30 (762)	16 (406)	36 (914)	10 (254)	3 (76)	240/240	9600	17.0 (2.6)	1/2 (13)	18.0 (8.2)	14.9 (6.8)	Standard	VS_12A30T ^②
	36 (914)	16 (406)	42 (1067)	10 (254)	3 (76)	240/240	11400	16.8 (2.6)	3/4 (19)	19.2 (8.7)	16.1 (7.3)	Standard	VS_12A36T ^②
14 (356)	12 (305)	18 (457)	18 (457)	12 (305)	3 (76)	240	4400	16.7 (2.6)	1/2 (13)	11.4 (5.2)	7.7 (3.5)	Standard	VS_14A12T
	18 (457)	18 (457)	24 (610)	12 (305)	3 (76)	240	6600	16.7 (2.6)	3/4 (19)	12.9 (5.9)	9.4 (4.3)	Standard	VS_14A18T
	24 (610)	18 (457)	30 (762)	12 (305)	3 (76)	240/240	8800	16.7 (2.6)	1/2 (13)	16.3 (7.4)	12.7 (5.8)	Standard	VS_14A24T ^②
	30 (762)	18 (457)	36 (914)	12 (305)	3 (76)	240/240	11400	17.3 (2.7)	3/4 (19)	19.4 (8.8)	15.8 (7.2)	Standard	VS_14A30T ^②
	36 (914)	18 (457)	42 (1067)	12 (305)	3 (76)	240/240	13200	16.7 (2.6)	3/4 (19)	22.4 (10.2)	18.8 (8.5)	Standard	VS_14A36T ^②
16 (406)	12 (305)	20 (508)	18 (457)	14 (356)	3 (76)	240	5000	16.6 (2.6)	1/2 (13)	11.8 (5.4)	8.0 (3.6)	Standard	VS_16A12T
	18 (457)	20 (508)	24 (610)	14 (356)	3 (76)	240/240	7500	16.6 (2.6)	3/4 (19)	15.1 (6.8)	11.3 (5.1)	Standard	VS_16A18T
	24 (610)	20 (508)	30 (762)	14 (356)	3 (76)	240/240	10000	16.6 (2.6)	1/2 (13)	18.1 (8.2)	14.3 (6.5)	Standard	VS_16A24T ^②
	30 (762)	20 (508)	36 (914)	14 (356)	3 (76)	240/240	12800	16.8 (2.6)	3/4 (19)	22.3 (10.1)	18.5 (8.4)	Standard	VS_16A30T ^②
	36 (914)	20 (508)	42 (1067)	14 (356)	3 (76)	240/240	15000	16.6 (2.6)	3/4 (19)	26.4 (12.0)	22.6 (10.3)	Standard	VS_16A36T ^②

① Add Type number (Type 1 through 4) in the blank position in the code number. Example **VS106J06T**. For unheated units, see catalog [page 146](#).

Sinuated wire, high watt density units are provided with embedded sinuated elements and high emissivity coating, unless exposed sinuated is specified when manufactured. (These are **not stocked**.) Consult factory.

Overall length applies only to the full vestibule (Type 1) units. Types 2 and 3 are shorter by one Vestibule length. Type 4 length equals (B).

Type 2 (left vestibule) and Type 3 (right vestibule) style units are not stocked. They are, however, still standard units, and designs are kept on file.

All units have 2 ±1/4 inch thick walls.

All units in this table are suitable for use up to **1800°F (982°C)** maximum surface temperature.

② These units have dual elements, to be used in "parallel" for 240 volt usage. Alternate designs are available for 480 volt, 277 volt and three phase (internally wired). Consult factory.

Ceramic Fiber Products

Ceramic Fiber Heaters

How to Order

Made-to-Order Units

Ordering Information

Quantity: When ordering, specify quantity of units desired. Semi-cylindrical units are sold as "each half." Two to make the pair are usually required. Please include the number of desired spares or extras in the total quantity.

Code number: Unit code number, if an exact reorder of a previously designed made-to-order unit. Please reconfirm volts and watts, and lead orientation and length. Most stock and standard heaters allow selection of several stock modifications (see below) and also termination options (see pages 150 and 151).

Dimensions for made-to-order units:

As a minimum, use the dimensions (A, B, C, D, E, L, T) shown on pages 154 to 160. Include drawing if possible. Specifications: Heated area, width and length, overall width/length, thickness, electrical ratings, etc.

Wattage: 6.5 to 25 W/in² (1.0 - 3.9 W/cm²) on the heating surface is the recommended watt density range, for operation in the 1500 to 2200°F (815 - 1204°C) range. [Note: At the higher temperatures, lower watt densities must be employed.] Please provide operating temperatures and conditions. Consult Watlow for higher watt densities at other temperatures. Generally, for higher operating temperature limits, lower watt densities will have to be used.

Voltage: 60, 120 and 240V~(ac) are provided on the stock/standard units, but up to 600 volts is possible on made-to-order units. Internally connected three-lead, three-phase units are also possible on made-to-order units (these are normally internally wye-connected). Consult Watlow on special voltage requirements.

Leads: Lead length and orientation (i.e. Style A, B or C). (Lead Style A, 12 inch (305 mm) long is standard.)

Shipping weight: The product listing tables show net weights per unit. To estimate gross shipping weight, add another 30 percent to the total. Additional shipping/packaging charges may be incurred for certain large orders. Due to the light weight but large sizes of these heaters, "DIM" (dimensional box weights) weighting may occur on expedited air shipments.

Modifications

It is possible to order certain special modifications to stock and standard units prior to shipment. Some of these are listed below, with a brief description.

Beveled and trimmed edges: The unheated edges of Type 6, 7 and 8 units can be factory modified to provide in-between overall sizes, and can also be angle cut to form regular polygon shapes around objects. Angles between zero degrees and 45 degrees can be accommodated.

Black surface coating: Improves the emissivity of the heater's

hotface, see graph on page 146 for emissivity values and consult factory for pricing adders.

Leads: Besides length and orientations, see page 151 for other "Special Add-On Lead" configurations.

Thermocouple holes: Ceramic tubes on page 151 are used to make electrically isolated holes through heaters. To order, the inside diameter and location must be specified. Also, a special "behind-the-element" horizontal thermocouple tube is available, to very closely track element temperature for over-temperature protection and improved heater life.

Notches or long slots in no-heat areas of units: Rectangular and semi-circular notches can be cut into no-heat areas and vestibules on most units. Normally, a sketch or drawing that specifies exact location must be included with your order. Fax numbers to send drawings to are available.

Shortened vestibule lengths: Modified vestibule lengths require retaining at least ½ inch (13 mm) of insulation for adequate strength, or completely removed ("0" length) to make Type 1 units into left vestibule (i.e., Type 2) or right vestibule (i.e., Type 3) units.

Lead Times

Stock: Same or next working day shipment, subject to current inventory (consult factory for latest

status). No set up charges. Orders must be placed before 2:00 p.m., CST/CDT, USA.

Stock with modifications: Two to three working days shipment. Nominal set up charges only for

specific modifications, not for the basic heater.

Standard: Shipment normally within four weeks, but check with factory for latest lead time status. No set up charges.

Ceramic Fiber Products

Molded Ceramic Fiber Insulation Modules

For heating applications requiring insulation panels, Watlow makes available many shapes and sizes of stock, standard and made-to-order molded ceramic fiber insulation modules. These insulation modules are made of the same high quality, high temperature, low mass ceramic fiber material used in our heaters.

As a complement to the overall product line, these modules offer additional avenues to solve high temperature industrial insulation problems. Furthermore, without heating elements, molded ceramic fiber insulation modules can come in more complex shapes to conform to application requirements.

Molded-to-shape insulation modules also make handling and installation easier compared to other insulation methods. Since these are molded to shape, sanding, cutting and grinding of blocks to achieve the desired configuration is not required.

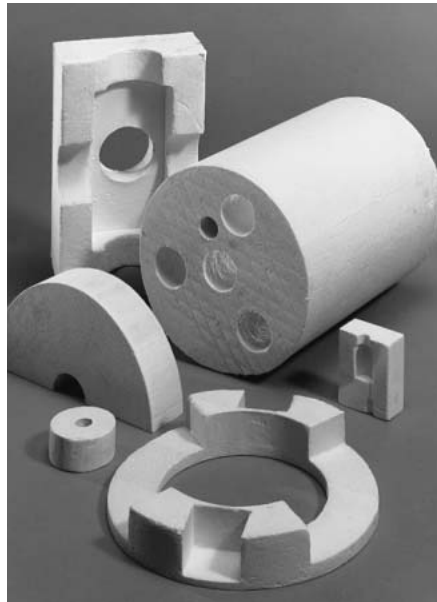

Highly resistant to thermal shock and chemical attack, except for hydrofluoric and phosphoric acids, and strong alkalis, insulation modules are unaffected by oil and water. If the insulation gets wet, physical and thermal properties can be fully restored when dried.

Note: If using molded ceramic fiber insulation modules along with other Watlow ceramic fiber **heaters**, oil, water and other contaminants can and will negatively affect the heating element portion of the ceramic fiber heater.

Molded insulation modules are rated for up to 2300°F (1260°C) continuous duty. The inorganic binder eliminates smoke or combustion during initial heating to 300°F (150°C) and above. Vacuum molded density is 10 to 15 lbs/ft³ (160 to 240 kg/m³), same as the ceramic fiber heaters.

Size Limits: Maximum flat size is 34 x 52 inches (860 x 1320 mm) with a molded thickness of more than four inches (102 mm). Maximum inside diameter for semi-cylindrical modules is 24 inches (610 mm). For applications requiring curved insulation pieces in excess of 180 degrees, consider using multiple arc-section modules or an array system of multiple flat units.

Application and Technical Data

The same insulation performance and technical data of ceramic fiber heaters applies to molded ceramic fiber insulation modules. For specific information of insulation performance properties, see the *Heat Loss and Energy Transfer* portion of the ceramic fiber heaters section on [page 146](#)

Accessories

Where appropriate, many of the same accessories for ceramic fiber heaters are available for use with molded ceramic fiber insulation modules. These accessories can be used to modify, provide mounting options, and effect minor repairs and maintenance. For details, turn to [pages 151 and 152](#).

Ordering Information

Stock and Standard: Molded ceramic fiber insulation modules are

available in exactly the same sizes and shapes as the ceramic fiber heaters listed in the previous ordering tables. In general, the ordering code numbers of these insulation modules are derived by replacing the second alpha character in the heater code number (i.e., F, S, C, R, etc.) with **N** to designate **no-element**.

Made-to-Order: Watlow sales engineers can work with customers to design and manufacture modules to meet specific insulation needs.